

ARBTRAK 150

OPERATORS MANUAL



SECTION	Title
1	Introduction and Purpose
2	Technical Specifications, Dimensions Noise Level, and Lifting points
3	Safety and Symbols
3.1,3.2,3.3	Ensure! Never! Always!
3.4	Safety controls and switches
3.5	Control cut-outs
3.6	'No Stress' system
3.7	Tracking Controls (ArbTrak)
3.8	Symbols
4	Machine Preparation
4.1	Fuelling and parking
4.2	Infeed chute
4.3	Trailer adjustment (If applicable)
4.4	Discharge chute
4.5	Work Position
5	Operation
5.1	Pre-work checks
5.2	Starting machine
5.3	Stopping machine
5.4	Blockages
5.5	Moving tracked model (ArbTrak)
5.6	Preparing for Transport on completion of work
5.7	Operating Hints
6	Maintenance
6	Routine Maintenance Schedule
6.1	Lubrication points
6.2	Engine Oil
6.3	Coolant
6.4	Hydraulic Oil
6.5	Fuel level
6.6	Drive belt check
6.7	Chipper Blades

- 6.8 Radiator
- 6.9 Drive Belt replacement
- 6.10 Steam cleaning
- 6.11 Air cleaner
- 6.12 Electrics
- 6.13 Battery
- 6.14 Wheels and Tyres (trailer only)
- 6.15 Brakes (trailer only)
- 6.16 Bearings and pivots
- 6.17 *Spare number not used*
- 6.18 Hydraulic connections
- 6.19 Mountings
- 6.20 Hydraulic return filter
- 6.21 Hydraulic Oil change
- 6.22 Fuses and No Stress system
- 6.23 Fault finding chart
- 6.24 Chipper Disc blade regrinding data

7 Storage and Disposal

- 7.1 Storage
- 7.2 Removal from storage
- 8 Disposal

Appendix

- Hydraulic Circuit
- Electrical Circuits
- Certificate of Conformity
- Risk Assessment
- Noise Assessment
- Parts List
- Transcript of HSE leaflet 604

ArbTrak 150 Model 1. INTRODUCTION AND PURPOSE 1-1

INTRODUCTION

This manual explains the proper operation of your machine. Read these instructions thoroughly before operating and maintaining the machine. Failure to do so could result in personal injury or equipment damage. Consult your GreenMech supplier if you do not understand the instructions in this manual.



CAUTION! This symbol indicates important safety messages in this manual. When you see this symbol, be alert to the possibility of injury to yourself or others, and carefully read the message that follows.

Keep this manual in the box provided and treat as part of the machine. Locate and note here the serial number and quote it in any communications. This is important when ordering spares. Remember to include all numbers and letters.

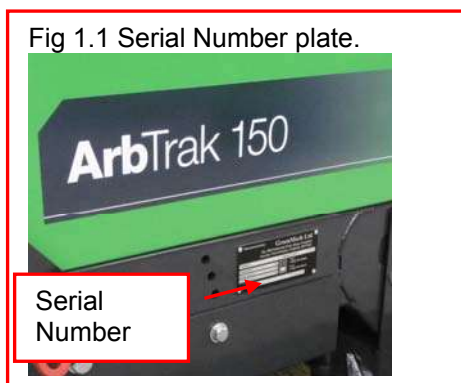

VIN Number.....

Serial Number.....

Write in the number!

This manual covers the following models.

ArbTrak 150 track mounted chipper – stop bar, diesel engine

The information in this manual is correct at the time of publication. However, in the course of development, changes to machine specifications are inevitable. Should you find any information to vary from the machine in your possession please contact your GreenMech dealer for up to date information.

This manual may contain standard and optional features and is not to be used as a machine specification.

PURPOSE



CAUTION! This machine is designed solely to chip wood and must not be used for any other purpose. The machine should only be used by trained operators who are familiar with the content of this instruction manual. It is potentially hazardous to fit or use any parts other than genuine GreenMech parts. The company disclaims all liability for the consequences of such use, which in addition voids the machine warranty.

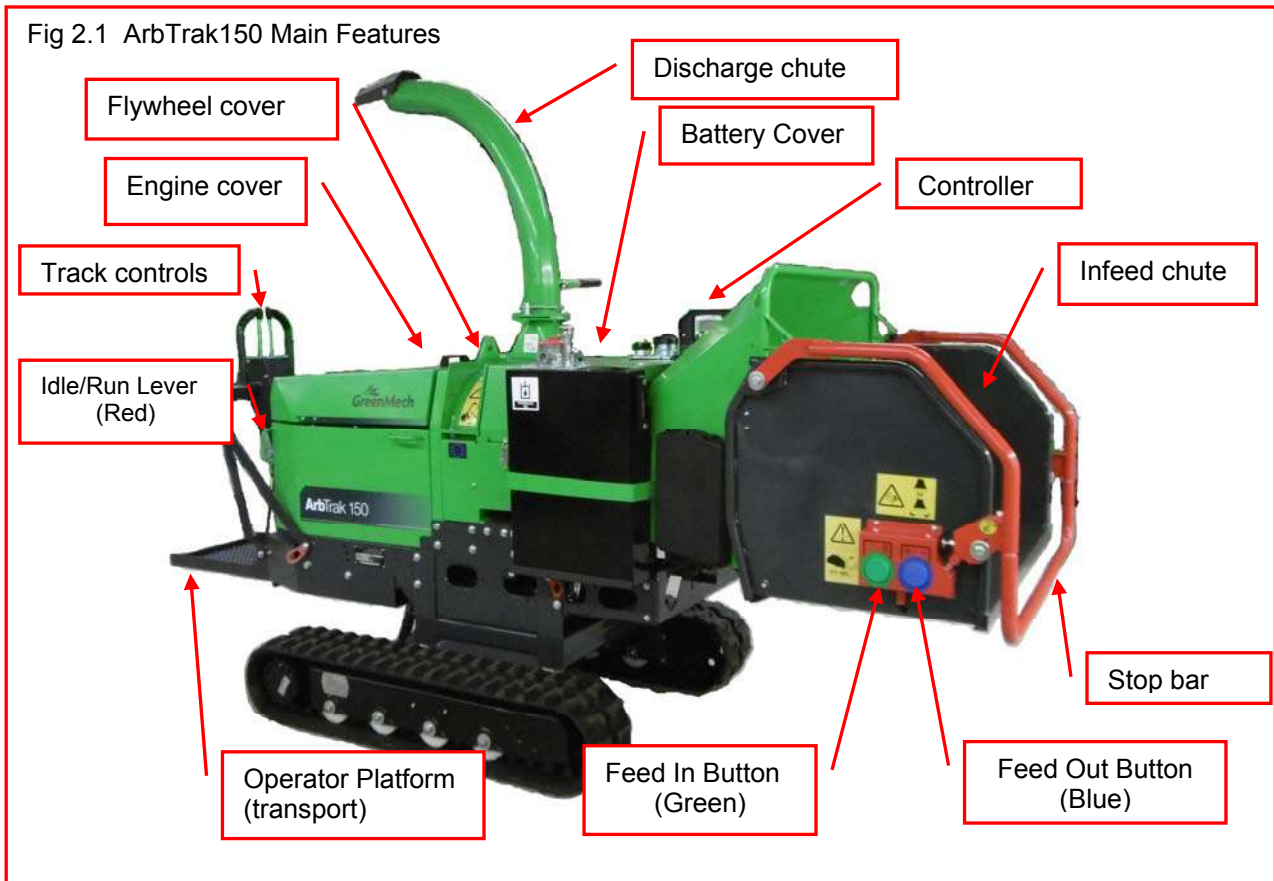

TECHNICAL SPECIFICATIONS ArbTrak 150 Track mounted model	
Max Capacity	230mm X 160mm (9inch x 6inch)
Infeed Chute	970mm x 790mm
Chipper Flywheel	500mm x 25mm
Speed	1700 rpm
Chipping Blades	4 round disc blades
Feed Rollers	2 x Hydraulic
Power Control	No-Stress Electronic Feed Roller Controller
Hydraulic capacity	30 Lt
Fuel Capacity	27Lt
Power Units	34HP Kubota diesel
Track Size	1450mm x 230mm x 300mm
Ground Pressure	0.203kg/cm2 - 2.88psi
Sound Power Lwa	115dBa
Sound Pressure LPa	92dBa
Length (Work)	3420mm
Width	1175mm
Height (Work)	2470mm
Weight	1050kg

Noise

Noise levels vary depending on type of material being processed. Also duration of operation is variable. Noise emission tests have been carried out and the guaranteed sound power level (Lwa) is displayed on the CE plate of each model as follows:

ArbTrak 150 - 115dB(A)

Minimise noise by switching to idle or stopping the engine whenever chipping is not in progress.



CAUTION! Operators must wear appropriate ear protection. Bystanders must be kept away from proximity of machine.

Lifting Points

There is a single central lifting point by the base of the discharge chute.



CAUTION! Lift with extreme care. The machine may tilt because the single lifting point may not be directly over the centre of gravity.

**3.1 ENSURE! :**

All Operators must be fully trained in the use of their machine.
(*Certificated Operator training courses are available on request.*)
Operators Manual is read and understood.
Enclosed HSE guidance notes are read and understood.
Appropriate Personal Protective Equipment (PPE) is worn, including non-snag clothing, gloves, eye and hearing protection.
Machine is positioned on level ground and machine is level with infeed chute at not less than 600mm (23.62 inches) above ground level (fig 3.4.3).
All guards are fitted and in good condition.
Blades are in good condition and secure.
All blades are sharpened or replaced in "Sets".
All fasteners are checked regularly for tightness.
Only "WOODEN" materials free of nails etc., are fed into machine.
Correct First Aid Kit including large wound dressing is available on site.
Fire extinguisher is available on site.

**3.2 NEVER! :**

Work on machine until chipper flywheel is stationary and engine or PTO has stopped.
Operate machine without protective clothing (Eye protection, Earmuffs, and Gloves), or high visibility clothing when working on roadside.
Operate with loose articles of clothing, including loose cuffs on gloves.
Work under a raised component without adequate safety support.
Operate machine with untrained personnel or with individuals present who are not involved in chipping work operation.
Leave machine unattended with engine running at full operating speed. (See section 4)
Put any part of your body into infeed chute while machine is running.
Operate machine whilst under the influence of alcohol or drugs.
Operate machine inside a building or confined space.
Climb on infeed chute.
Impede or obstruct Stop control.

**3.3 ALWAYS! :**

Check machine before starting (see Section 4 Preparation and Section 5.1 Operation: Pre-work checks).
Be aware of potential hazards in work area, i.e. uneven ground, tree roots, trip/slip hazards, obstructions and type of materials being fed into machine.
Feed from a side.
Keep clear of discharge area.
Have a second trained operator within easy reach of machine.
Maintain strict discipline at all times.
Service machine at specified periods. (see Section 6: Routine Maintenance).
Note direction of discharge chute and if necessary note wind direction to prevent debris from being blown into highway or where it could affect members of the public.
Keep machine level.
Check route to worksite for gradients, undulations and obstructions.
Remove key before doing any maintenance.

3.4 Safety Controls and Switches

Emergency Stop/Control Bar (fig 3.4.1)

In the event of an emergency, push stop bar to STOP feed rollers.

Once the emergency has been rectified, press Green button to restart rollers to continue Feed In or press and hold Blue button to Feed Out to eject material. Stop bar returns to work position but does not restart feed rollers. If stop be tripped accidentally in normal working conditions, i.e. NOT an emergency, then Feed In can be recovered by pressing Green button. To reverse feed rollers (Feed Out) press and hold Blue button. To regain Feed In in press Green button.

Fig 3.4.1 Stop Bar and Feed control Buttons



Engine Stop button (fig 3.4.2).

To stop engine, press red stop button on control unit, and/or turn key anticlockwise to '0' position. To restart, reset key clockwise to 1. To disable machine, remove key.

CAUTION! Do not restart engine until hazard has been removed.

Fig 3.4.2 Engine Stop/Start

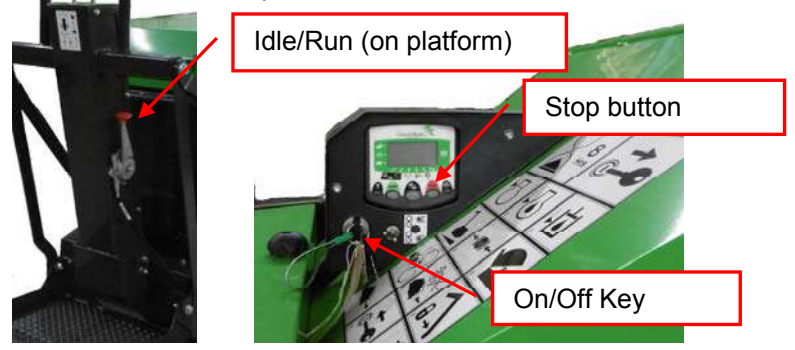
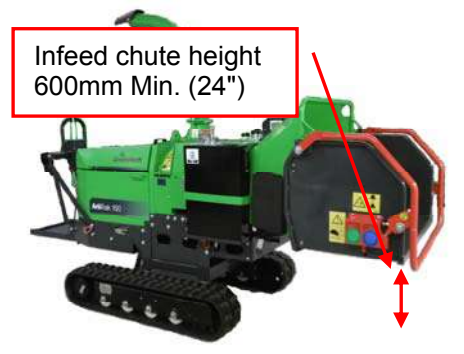

Fig 3.4.3 Infeed chute height



Infeed chute height

CAUTION! Ensure Infeed chute is at correct safety height.

3.5 Control cut-outs

Cut-out switch under engine cover prevents starting with covers removed. Engine overheating is protected by thermal cut-out switch in coolant circuit. Low engine oil pressure is protected by pressure switch in engine oil pump.

3.6 No Stress system

Speed sensor disables feed roller FEED IN or FEED OUT mode when engine speed is below factory pre-set value. Overload sensor stops and restarts rollers during Feed In.

3.7 Tracking Controls

A two position toggle switch selects either tracking or chipping. In track mode No Stress system will not allow feed rollers to operate.

At Chip – Track select Track for tracking motion (Fig 3.7.1)

Lever controls operate drives to tracks. (Fig 3.7.2) Push for forward motion. Pull for reverse motion. Use hand throttle Idle/Run (fig 3.7.2) to control travelling speed.

Note: Chipper flywheel runs whenever engine is running.

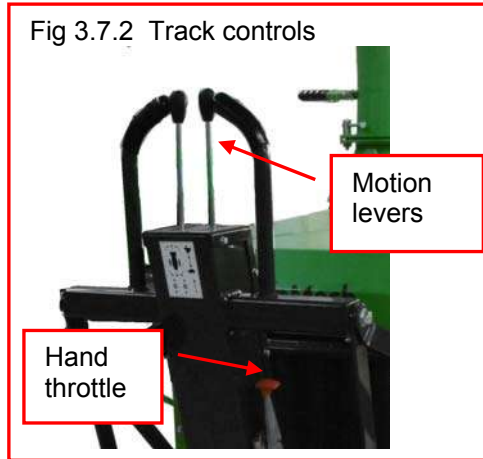
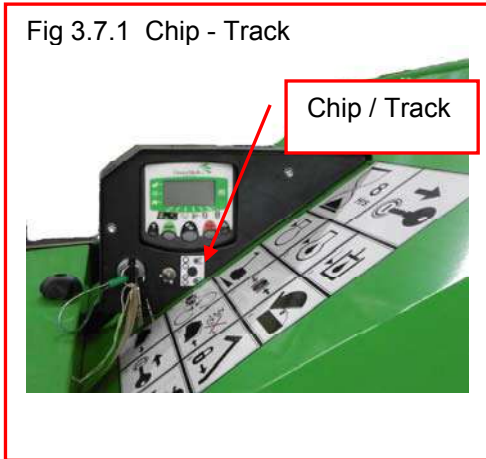

3.8 SYMBOLS on the MACHINE

These relate to operator safety, correct use and maintenance of machine. Check that all personnel understand and are familiar with meanings before using machine.

Important Safety symbols

Take correct action shown on display box below stated hazard box (see table)



Caution!		Remove Key		Do NOT start engine	
Caution!	Beware flying object hazard	Beware noise hazard	Beware trapping hazard	Brakes off -incorrect	
Read instruction manual	Wear helmet & visor	Wear ear protectors	Wear proper clothes	Brakes on -correct	
Machine not level -incorrect	Beware flying object hazard	Beware flying object hazard	Beware exposed drives hazard	Caution!	
Machine level -correct	Keep bystanders away	Position and lock discharge chute	Fit all guards	Keep nuts tight	

Important Operating Checks Notice

Before use carry out daily stated checks in order shown (see table)

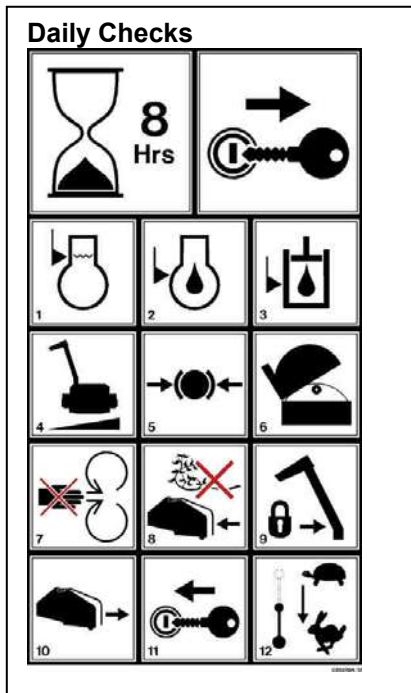

Every 8 Hours – Daily checks		Remove key stop engine
1. Check coolant level	2. Check engine oil level	3. Check hydraulic oil level
4. Check machine is level	5. Check brakes are on	6. Check chipper flywheel is clear of debris
7. Check all guards are in place	8. Check infeed chute is clear of debris	9. Lock discharge chute
10. Check stop bar	11. Start engine	12. Increase from Idle to Run

Important Safety Information

Caution! Beware of thrown object hazard

Action: Stand to side of infeed chute, NOT in centre.

Caution! Beware of thrown object hazard

Action: Keep away from fast discharge chute

Face shield must be worn

Wear face shield

Lift Point

Sound level

LWA
120 dB

Ear defenders must be worn

Ear defenders must be worn

Wear ear protectors when operating this machine

Caution!

Do not climb into infeed chute

Caution! Infeed chute trapping hazards

Keep hands clear. Do not climb in

Caution!

Do NOT operate with infeed chute at less than 600mm from ground.

Transport Lock

Lock this component before moving machine

Caution! Beware Crushing hazard!

Do NOT work or park directly up or down slope.

Caution!

Do NOT drive up or down slopes of more than 20°

Maintenance Information

Radiator cleaning

8 Hours Check radiator screen	40 Hours Blow out radiator core

Diesel Filler

Hydraulic Filler

Grease point

40 hours / weekly

High temperature Grease 40 hours

High Temp Grease

Operating Information

Chipper Flywheel cleaning

Caution!	Read Manual!	Remove key
Caution! Sharp edges	1) Wear protective gloves	2) Release cover bolts
3) Open chipper covers	4) Lock / Block flywheel	5) Clean blade nut and bolt recess
6) Remove blade nut	7) Clean blade spigot and flywheel recess	8) Replace and Tighten to 200Nm
9) Replace all covers	10) Secure covers	11) Replace key

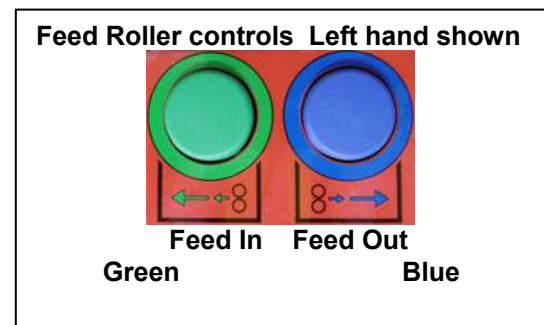
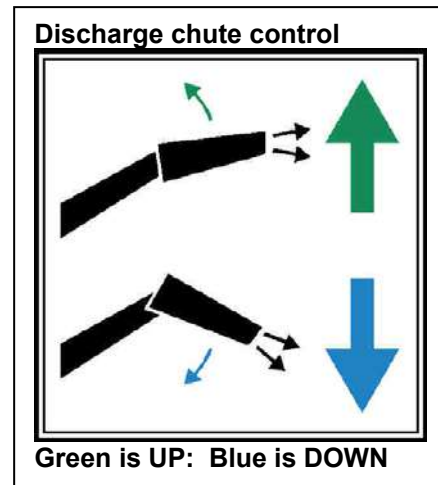

Additional operating controls for tracking ArbTrak model

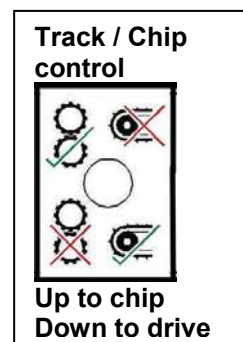
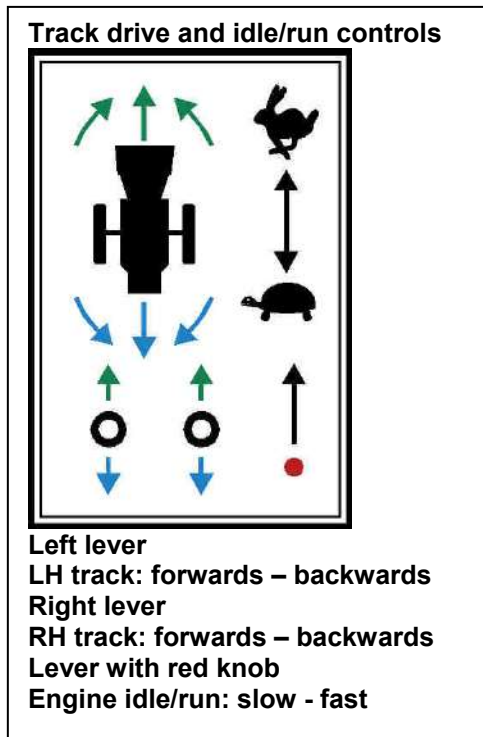

4.1 Initial Fuelling and Parking

Fill fuel tank with correct fuel (Fig 4.1).
 Top up hydraulic tank if necessary, with correct oil.
 See Section 6.

Fig 4.1. Fuel Tank



4.2 Infeed Chute

Position machine so that body is level.
 1) Release infeed chute catches (fig 4.2), and gently lower infeed chute to work position.
 2) Check height of infeed chute for safe working height (Fig 3.4.3)

Fig 4.2 Infeed Chute Catches

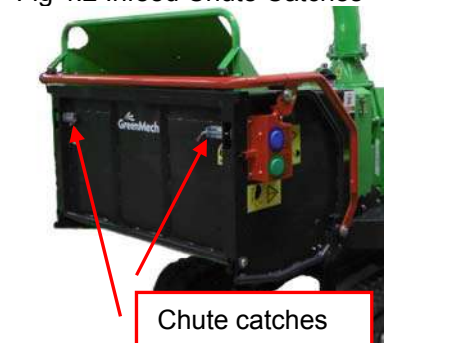

CAUTION! Infeed chute must not be used at less than 600mm from ground.

4.3 Trailer Adjustment

If chipper used on trailer (not recommended):
 1) Apply vehicle handbrake. If trailer is detached from vehicle, set jockey wheel clamp to allow jack screw to lift drawbar clear of vehicle hitch, apply trailer handbrake and chock wheels.
 2) Set drawbar jockey wheel height to level machine body at correct infeed chute height.

4.4 Discharge Chute (Fig. 4.4)

Release swivel clamps, point chute in desired direction and tighten clamps.
 Set flap at desired height and tighten clamp.

Fig 4.4. Discharge Chute

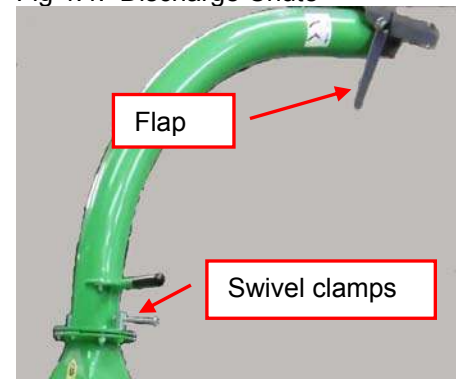

CAUTION! Do not point discharge chute towards infeed area.
CAUTION! When **tracked model** is driven on tracks, ensure chute points away from driver.

4.5 Work Position

Ensure discharge chute is pointed away from operator.

5.1 Pre-Work Checks:

Check machine is stationary, Key in OFF position or removed.
 Check that machine is level and infeed chute is not less than 600mm from ground (fig 3.4.3).
 Check engine oil level (See Engine instruction manual).
 Check hydraulic oil level (See Section 6).
 Check fasteners for tightness and hydraulic connections for leaks.
 Check condition of blades as follows:

Undo bolt on chipper flywheel cover.
 Raise engine cover. Check nothing is rotating.
 Remove bolt retaining chipper flywheel cover.
 Using discharge chute handle as a lever, swing back cover onto stop to expose chipper flywheel and blades. (fig 5.1.1)

CAUTION! Beware sharp edges of blades and unexpected movement.

Note: Locking pin will spring towards chamber to prevent flywheel from turning.
 Retract locking pin and carefully rotate chipper flywheel to check tightness of blade bolts and condition of blades (fig 5.1.2).

Remove any loose wood material.
 If any bolts are loose, refer to Maintenance Section 6.7 for further action.
 Retract and hold locking pin and replace chipper flywheel cover. Tighten all bolts securely.
 Remove any loose material and dust from radiator and engine bay
 Replace all covers and secure.

Check discharge chute is in desired position pointing away from infeed and all clamps are tight. (see Section 4.4)
 Check work area and erect signs and cone off discharge area if necessary.
 Check **ALL** safety procedures have been followed.

CAUTION! Always work with chipper level, preferably with the infeed direction slightly down the slope to minimise the risk of material falling back out.

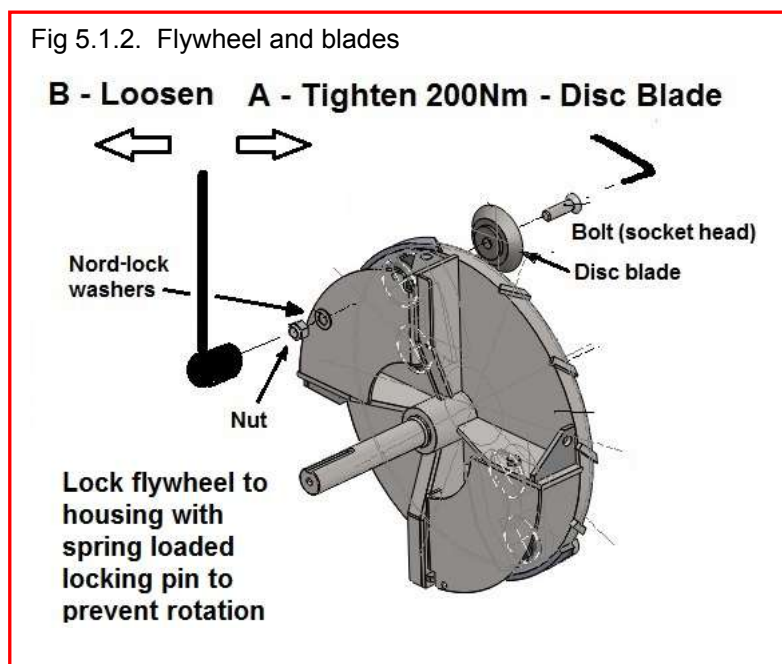
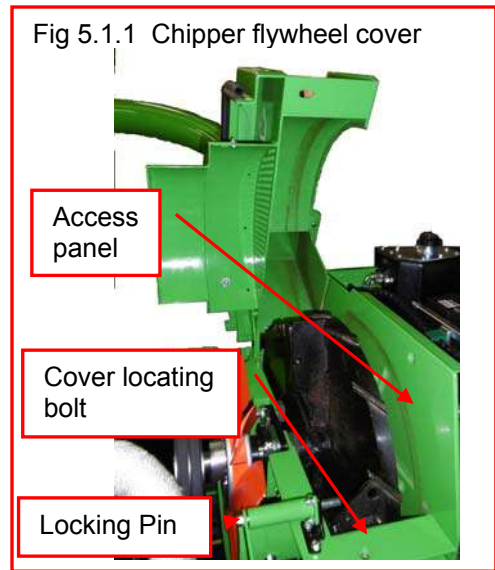

5.2 Starting Machine (Fig 5.2)

CAUTION! Beware sharp edges and dust. Wear protective gloves and eye shield!

Check all other personnel are clear of machine.

Diesel Engine (Fig 5.2.1 Fig 5.2.2)

Turn the ON - OFF key to position I. Wait for the pre-glow countdown to cease and chipper speed 0 rev/min to be displayed.

Press green START button to start chipper. Set Chip – Track to ‘Chip’

Move hand IDLE/RUN lever to increase speed to operating speed.

Press Green Feed In button when ready to start loading chipper.

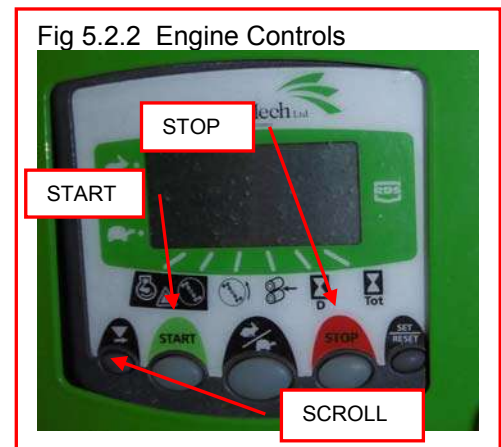
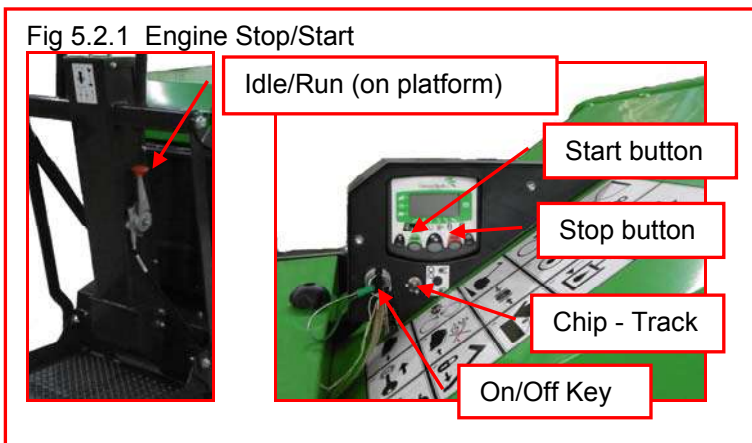

5.3 Stopping Machine

- 1) Push Stop bar to STOP feed rollers.
- 2) Set Idle/Run lever (fig 5.2.1) back to IDLE and allow chipper flywheel to slow down.
- 3) Press red STOP button to stop engine.
- 4) Switch ON - OFF key to position 0.
- 5) Wait for chipper flywheel to stop.

CAUTION! Chipper flywheel will take several seconds to stop due to its inertia.

5.4 Blockages

Stop engine and REMOVE key to secure place.

CAUTION! Chipped material is inflammable. Expect large volume and prevent from falling into engine compartment. All material must be removed.

Open chipper chamber. See 5.1 Pre-work checks.
 Look into chamber to identify problem if possible, before reaching in.
 Open discharge chute and fold down at hinge to inspect and clear.
 Clean out discharge chute thoroughly with a suitable rod to pass around bends as necessary.

CAUTION! Beware sharp edges of blades and unexpected movement of flywheel due to resistance of engine. Wear protective gloves.

Check if chipper flywheel is free to rotate. Pull top of flywheel in operating direction of rotation. If so proceed to 6 below.

If flywheel does NOT rotate freely, proceed as follows:

- 1) Loosen nuts to release feed roller spring (Fig 5.4) and pull roller away from fixed roller.
- 2) Inspect blades from infeed chute and if necessary enter with care to clear material.
- 3) Carefully remove excess loose material from around chipper flywheel and note any obstructions.
- 4) Carefully rotate chipper flywheel in reverse direction by full revolution to release blocked material. Use bar against paddle blades for aid.
- 5) Carefully remove all material, checking for obstructions.

Check rotation of chipper Flywheel.

Check condition of blades. See 5.1

Note: Always attempt to find reason for blockage. e.g. blunt blades, slack drive belts.

- 6) Re-assemble all covers with correct fasteners and check for security.
- 7) Start machine as 5.2 and check operation.

Note: If machine will not run, repeat process or contact dealer for technical advice.

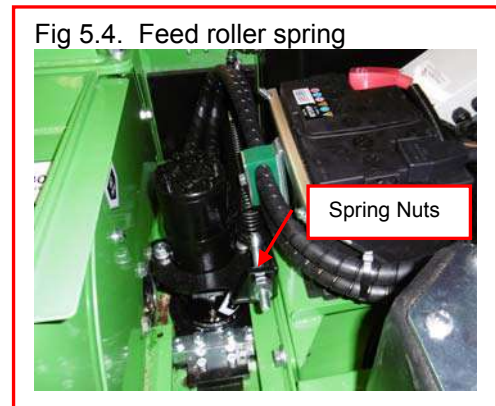

5.5 Moving ArbTrak

Set Chip - Track to Track (Fig 5.2.1)

Push both motion levers together to start forward movement (Fig 5.5).

Adjust Idle/Run lever to increase speed and decrease speed.

Push left or right lever to steer.

At work site ensure body is level.

Adjust Idle/Run lever to slow engine.

Note: Drive with track motors at rear when possible.

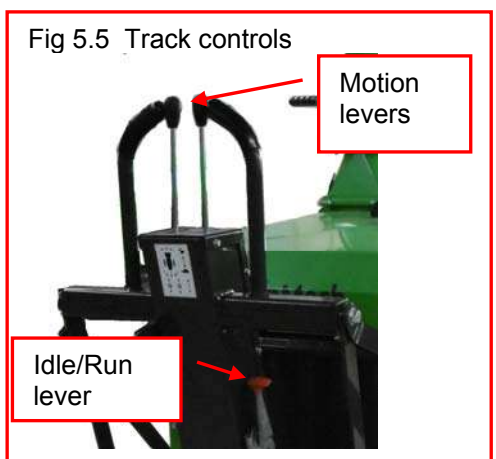

Cautions for ArbTrak tracked model

CAUTION! Do not leave machine parked directly up or down slope.



CAUTION! Avoid static turns on hard surfaces. This will rapidly wear tracks



CAUTION! Point discharge chute away from driver. Over long journeys, engage chipper drive to blow out build up of exhaust gas.



CAUTION! Do not drive directly up slopes exceeding 20 degrees. Slopes up to 30 degrees may be traversed with care.

5.6 Preparing For Transport On Completion Of Work (Fig 5.6)

Check that engine has stopped and chipper flywheel is stationary.

Remove surplus material from infeed chute and all machine surfaces.

Unlock and remove covers to remove debris.

Replace and secure covers.

Fold up infeed chute and secure catches.

Swivel discharge chute against stop towards infeed to direct away from driver platform, and secure.

Fig 5.6 Transport position

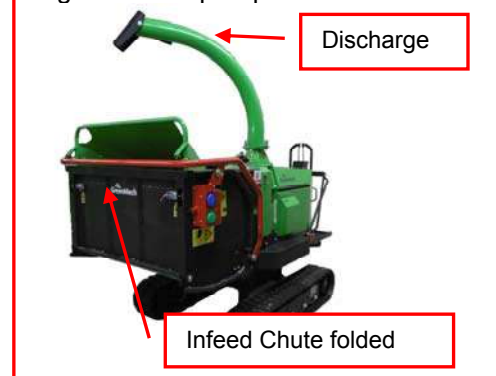
**5.7 Operating Hints**

Check that chipper flywheel is at full speed, rpm readout should be above 1700 rpm.

NOTE: “No Stress” system will only allow FEED IN (Forwards) and FEED OUT operation of feed rollers when machine is running at FULL operating speed and not overloaded.

Reduce chipper speed to IDLE whilst further material is collected for chipping.

Take care when feeding wood into machine to allow for awkward shapes to “KICK” when contacting feed rollers.

Position end of larger sections of wood inside infeed chute and then support other end whilst pushing wood into feed rollers.

NOTE: If chipper becomes blocked do not continue to feed. It will make removal of blockage more difficult. See 5.4.



CAUTION! Do not release discharge chute clamps when chipping is in progress. Elevation of discharge is altered by means of adjustable flap (fig. 4.4).



CAUTION! Keep working area around the machine clear at all times and check only authorised personnel are present.

ROUTINE MAINTENANCE SCHEDULE

 **CAUTION!** Always remove key and check for rotation before carrying out any maintenance.

Note: Engine and drive covers are secured closed with a hexagon headed release requiring spanner. Replace and secure when task is completed.
Instructions refer to ArbTrak model.

Action	Section	Page
DAILY		
Check engine oil level and coolant (ref: engine manual)	6.2 – 6.3	6-4
Check hydraulic oil level	6.4	6-4
Check fuel level	6.5	6-4
Check all drive belts	6.6	6-4
Check condition of blades and retaining bolts	6.7	6-5
Note: Special tools may be required		
Clean radiator screen and around radiator	6.8	6-6
Check feed roller stop bar function	3.4	3-2
Check condition of tracks	Refer to track manual	
Check track gear, nuts, rollers and bearings	Refer to track manual	

First 50 hours		
Check drive belt tensions	6.9	6-6
Check battery levels	6.13	6-7
Check hydraulic connections	6.18	6-8
Check all mountings	6.19	6-8
Check feed roller stop bar function	3.4	3-2
Check wheel and tyre condition and pressures (Trailer only)	6.14	6-7
Check brake condition and operation (Trailer only)	6.15	6-7
Service engine	Refer to engine manual	

Weekly in addition to Daily actions		
Blow out radiator core with air line	6.8	6-6
Check drive belt tension	6.9	6-6
Steam clean machine	6.10	6-6
Clean air cleaner	6.11	6-6
Check electrical connections	6.12	6-7
Check battery levels	6.13	6-7
Check feed roller stop bar function	3.4	3-2
Check wheel and tyre condition and pressures (Trailer only)	6.14	6-7
Check and adjust brakes (Trailer only)	6.15	6-7
Grease all bearings and pivots	6.16, 6.1	6-8
Check hydraulic connections	6.18	6-8
Check all mountings	6.19	6-8

250 hours in addition to Daily and Weekly actions		
Check all fluid levels	6.2, 6.3, 6.4	6-4
Check condition of bearings and pivots	6.16	6-8
Service engine	Refer to engine manual	
Check axle mounting bolts for tightness	6.19	6-8
Check track gear units, rollers and bearings	Refer to track manual	
Replace return filter element	6.20	6-8

1000 hours in addition to 250 hour actions

Change hydraulic oil when replacing filter element

6.21

6-9

ENGINE MAINTENANCE**REFER TO ENGINE MANUAL****TRACK MAINTENANCE****REFER TO TRACK MANUAL****Recommended lubricants****Specification**

Hydraulic Oil

ISO 32

Grease

Complex grease EP2 (high temperature)

Engine

SAE 15W-40 APICD

6.1 Lubrication Points (see 6.14)

Fig 6.1b Lubrication points ArbTrak150 tracked model

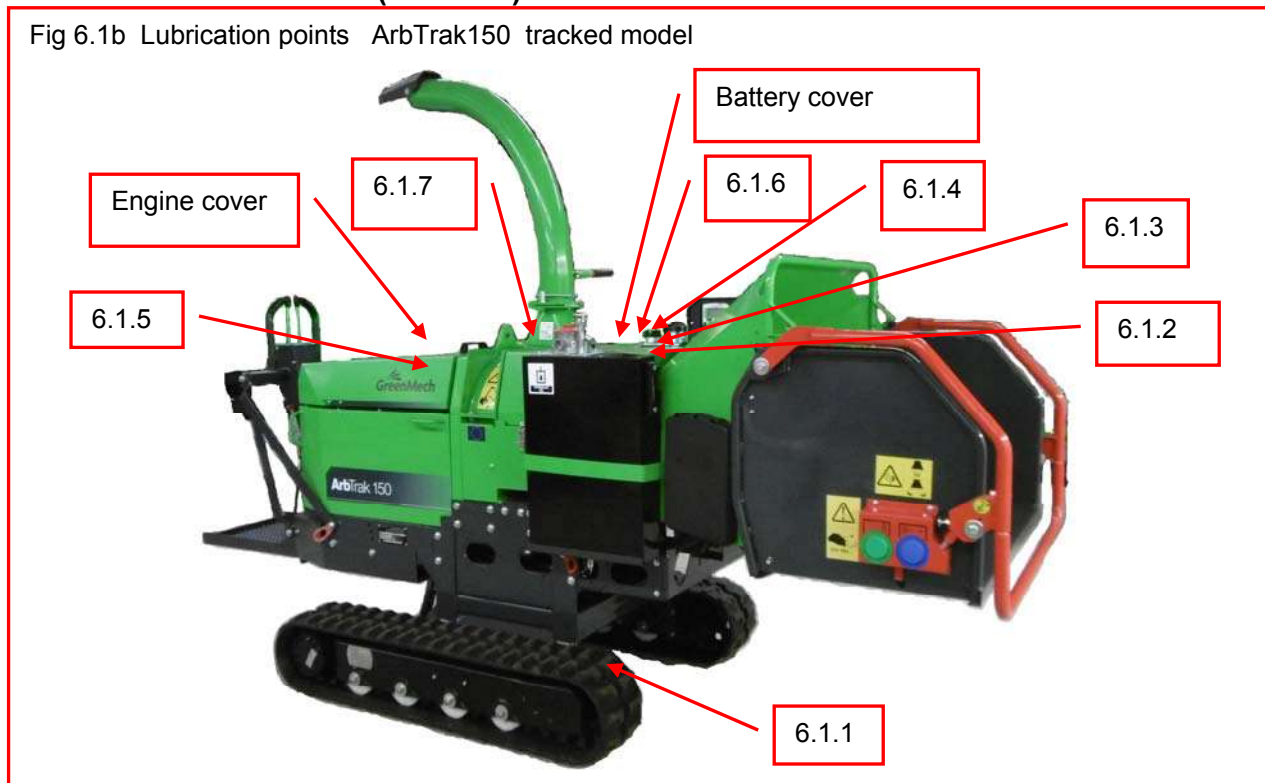

Grease except where stated

6.1.1	Tracks	See track manual
6.1.2	Feed roller slide	Clean and grease sparingly
6.1.3	Sliding Feed roller bearing	1 nipple under battery cover
6.1.4	Fixed Feed roller bearing	1 nipple under battery cover under hoses
6.1.5	Chipper flywheel front bearing	1 nipple (Fig 6.1.3) under flywheel cover
6.1.6	Chipper flywheel rear bearing	1 nipple (Fig 6.1.2) under battery cover
6.1.7	Chipper Flywheel labyrinth	1 Nipple in flywheel boss

Note 1: Do not over-grease bearings as damage to seals may occur.
40 hours requires only one full pump of hand operated cartridge gun.

Note 2: Use high temperature grease on chipper flywheel bearings

Detail of nipples under top and engine covers

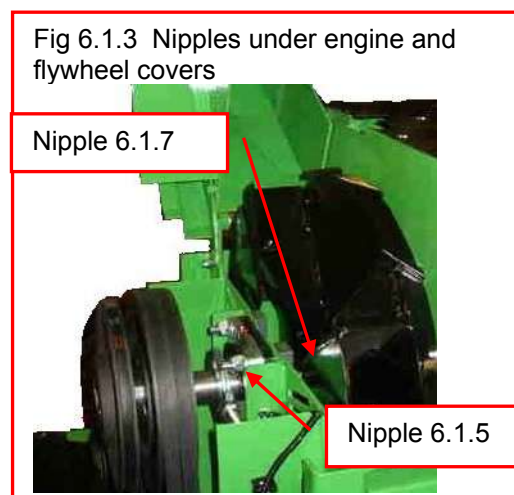
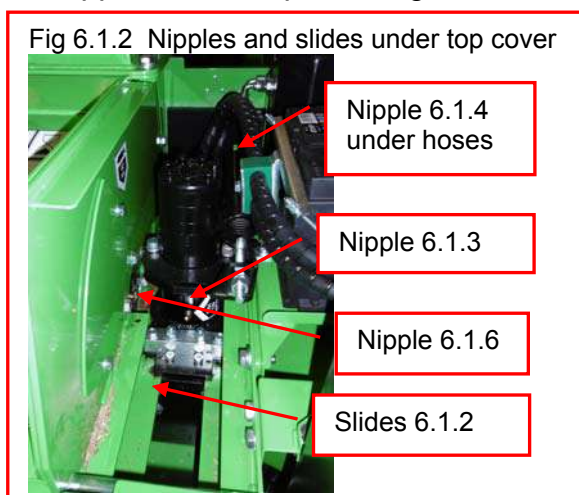

6.2 Engine Oil (Under engine cover)

Check daily (fig 6.2). Refer to engine manual to refill.

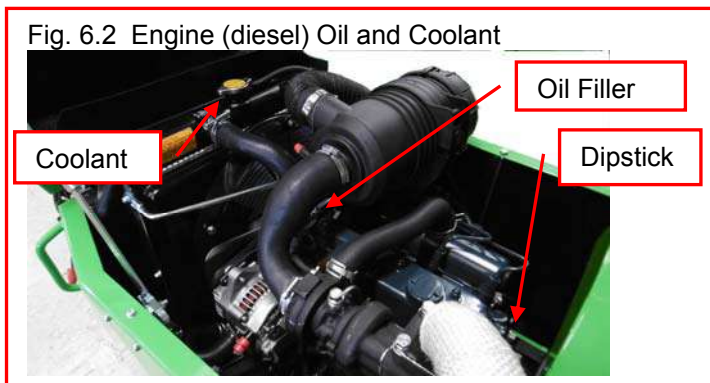

6.3 Coolant (under Engine cover)

Check daily, both radiator and overflow tank (fig 6.3). Refill as required. Check antifreeze.

CAUTION! Do not remove cap when engine is hot.

6.4 Hydraulic Oil

Check daily (fig 6.4). If below mark check for leaks and refill to correct level.

1000 hours. Remove drain plug, drain tank and refill with clean oil of correct specification. Replace filter (6.18)

6.5 Fuel Level

Check daily before work and fill as required.

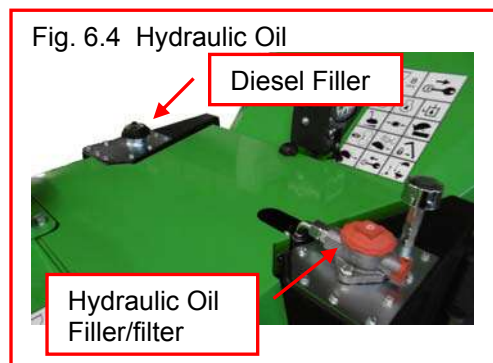

CAUTION! Use clean fuel only. If in doubt, use a funnel with a filter.

CAUTION! Do not use any form of synthetic fuel.

6.6 Drive Belts (Under engine cover)

Check daily before work, condition of all drive belts and replace if worn.

See section 6.9 for adjustment and replacement instructions.

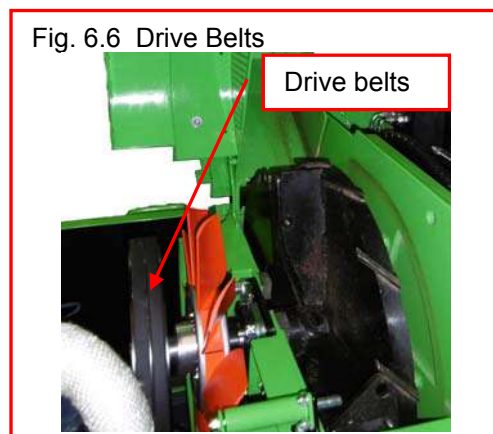

6.7 Disc Blade Cleaning - Replacement

Blade design permits relocation in at least two rotated positions before regrinding or replacement is required.

- 1 Check engine is switched off, and start key removed.
- 2 Raise engine cover, and check any rotation has stopped.

⚠ CAUTIONS for Blade cleaning

- Blades have sharp edges. Wear protective gloves.
- Flywheel paddles and vanes create shearing and trapping points at edges of exposed housing. Do not place hands or fingers on or near flywheel and housing edges.
- Flywheel rotation is resisted by engine compression in either direction. Beware unexpected movement when manually rotating flywheel between blade positions.
- Tools can slip if not fully engaged. Clean fasteners thoroughly before applying tools.
- Ensure flywheel is prevented from rotating when applying force to tools on blade fasteners.

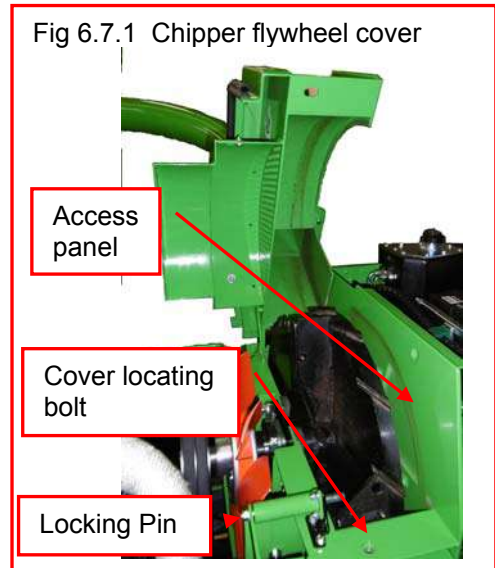

Follow procedure as on symbol instructions (Section 3.8):

- 1) Wear protective gloves.
- 2) Release access panels.
- 3) Using discharge chute handle as a lever, swing back cover on to stop to expose flywheel and blades. (fig 5.1.1 and fig 6.7.1). Flywheel locking pin will spring towards chamber.
- 4) Locate and retract flywheel locking pin, and carefully turn flywheel until locking pin engages hole in flywheel to prevent anticlockwise turn (viewed from blade nut).
- 5) Thoroughly clean debris from nut faces and bolt head socket (access panel engine side).
- 6) Using socket tool, loosen nut anticlockwise. Support blade bolt with hexagon key as required and remove blade and fasteners (fig 6.7.2).
- 7) Thoroughly clean debris from flywheel blade housing and all components to be replaced. Inspect condition of nuts and bolts and replace if any signs of wear. (Fig 6.7.3 and fig 6.7.4)
- 8) Replace blade with Nord-Lock washers ensuring that flywheel is blocked for opposite rotation. Tighten to correct torque: 200Nm.
- 9) Retract locking pin and carefully rotate to next blade and repeat next blade removal (from 4 above) until all blades cleaned and replaced securely.
- 10) Check all covers are secure.
- 11) Replace key to start machine.

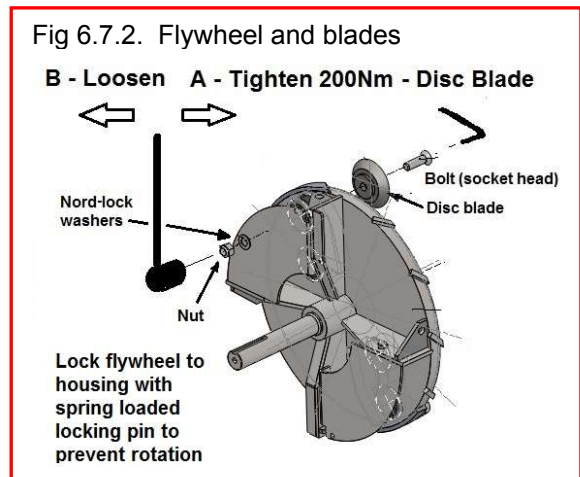

⚠ CAUTION! Blades must only be sharpened by grinding angled back face on a bench grinder. Grinding of front face will upset gap, which is factory set. Do not sharpen with hand held equipment.

All blades must be sharpened in “sets” with equal amounts removed to maintain balance. See 6.24 Note. If any blades are worn below flat annular section a complete set should be replaced.

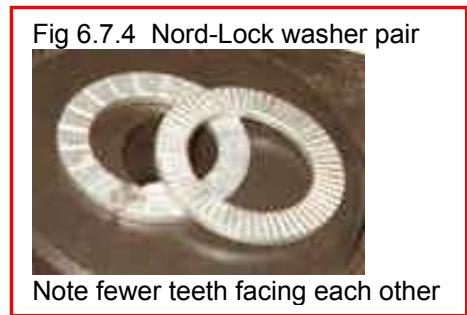

6.8 Radiator (under engine cover)

Daily

Check radiator for debris. (fig.6.8)

Lift out guard and clean.

50 hours or weekly

In addition to above, blow out radiator core from back with suitable airline and clear from front.

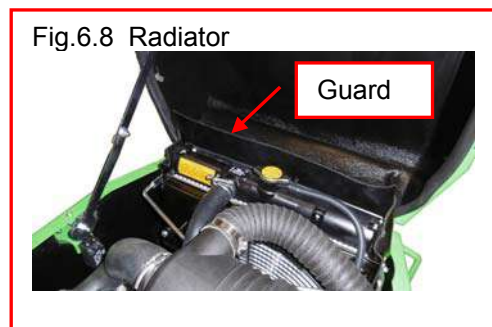

CAUTION! A build up of debris risks overheating of engine and a risk of fire.

6.9 Drive belts

Belt Replacement

Remove engine cover.

Chipper Drive

Belts are tensioned by weight of engine.

Place jack underneath engine or tray and raise until belts are sufficiently slack to be removed.

Check alignment and tension before starting chipper.

Pump drive

- 1 Remove chipper drive belts from engine pulley.
- 2 Release 2 bolts (Fig 6.9.2) in slotted pump mounting plate and release tensioner bar nuts to permit belt adjustment or removal.
- 3 Remove old belts and fit new set of belts ensuring they lay snugly in pulley grooves.
- 4 Re-tension belts using adjusting nuts and check tension

All models

- 5 Replace all covers and secure.

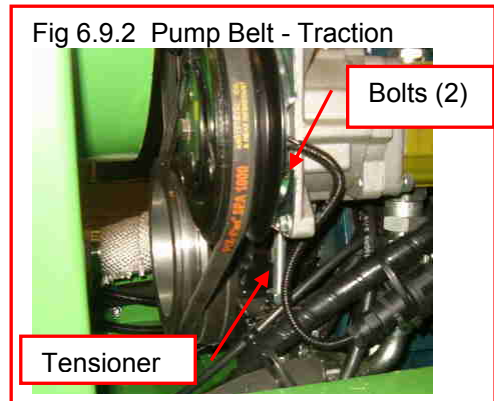

6.10 Steam Cleaning

Weekly and every 250 hours

- 1 Check all covers are fitted and closed.
- 2 Steam clean machine surfaces.
- 3 Clean electrical components with a damp rag, spray with WD40 and then wipe with dry rag.

CAUTION! Do not steam clean directly on to electrical components, e.g. control boxes.

6.11 Air Cleaner (under engine cover)

Weekly (Refer to engine manual)

- 1 Remove cover clips (fig 6.11) and release.
- 2 Slide out element and either blow out with air-line or gently tap on smooth ground to release debris.
- 3 Replace cover.



6.12 Electrical connections

Weekly

Check all wiring loom connections are secure.



CAUTION! Poor connections will affect engine security cut-outs and may prevent starting.

6.13 Battery

First 50 hours and weekly

- 1 Remove battery cover.
- 2 Release stays to access battery.
- 3 Check electrolyte level and top up if required.
- 4 Reposition battery, and secure stays.
- 5 Refit cover and secure.

Removal

- 1 First disconnect negative (-) cable (black cap).
- 2 Disconnect positive (+) cable (red cap).
- 3 Remove clamp and carefully lift out battery.
- 4 Replace by connecting positive cable before negative.
- 5 Secure battery as 6.13.4 above.

Fig 6.13 Battery



CAUTION! Gases are explosive. Electrolyte is corrosive. Avoid sparks and spillage.

6.14 Tyres and Wheels (Optional Trailer)

50 hours and 250 hours

Check condition of tyres.

Check pressures and inflate to 2.7bar (40lb/in²) pressure as required.

Check wheel nuts are tight to 110Nm (80lbf^t) torque.

6.14.4 Tyre sealant (Optional Trailer)

Tyres installed with Air-Seal Products water based sealant have either green valve cap or green ring around valve. Tyres will operate in same fashion as normal pneumatic tyre.

Note If valve core is depressed to deflate tyre, valve recess may become blocked with plug of sealant. To unblock either remove valve core to allow air to blow plug out or alternatively blow plug back into tyre with airline.

For replacement supply, consult GreenMech or distributor.

6.15 Brakes (Optional Trailer)

50 hours, weekly and 250 hours

Check operation and effectiveness of overrun and handbrake.

100 hours

Adjust brakes as follows

- 1 Chock machine, release handbrake fully off and check drawbar is fully extended.
- 2 Jack up both wheels and support on axle stands.
- 3 Remove inner bung (fig 6.15.1) to expose adjuster 'starwheel'.
- 4 Adjust starwheel with screwdriver until tight whilst rotating each wheel forwards until tight.
- 5 Slacken until wheel rotates freely in forward direction.

Fig 6.15.1 Brake adjustment



CAUTION! Reverse rotation of wheel may prevent correct adjustment.

- 6 Check brake linkage has 4 to 6mm movement at cable.
- 7 Repeat for opposite wheel.
- 8 Check balance bar is straight and pulls both cables evenly (fig 6.15.2).
- 9 Adjust ball nut to remove any slack from brake rod.

Note: Servicing of brakes may be required more often if above average mileage is covered. Refer to AL-KO brake manual or GreenMech for details for brake shoe replacement and other servicing

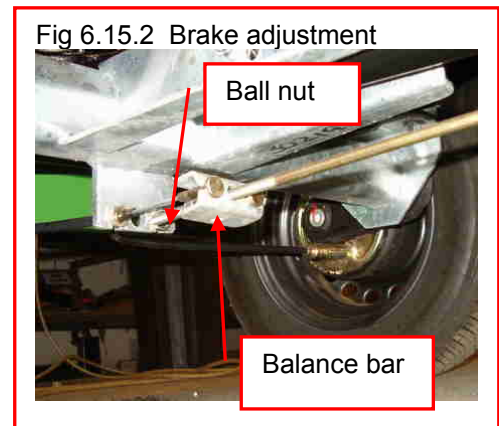

6.16 Bearings and Pivots weekly

See paragraph 6.1 for routine lubrication.

250 hours

Check rotating components for excessive movement and noise in operation.

Replace as required.

Note (Optional Trailer): Wheel bearings are maintenance free and do not require attention.

6.17 Paragraph number not used.

6.18 Hydraulic connections

50 hours

With circuit diagram to follow hose routings, check all hoses and connections for leaks and damage.

Replace any worn or damaged hoses with correct type and length.

Check routing before removal.

Replace hose free of strains, twists or kinks.

 **CAUTION!** Ensure any residual pressure is released before dismantling.

 **CAUTION!** Ensure hoses are refitted free of twists and kinks.

6.19 Mountings

250 hours

Check that all mounting bolts are tight.

6.20 Hydraulic Return Filter

250 hours (Fig 6.20)

- 1 Check oil is cool.
- 2 Unscrew filter cover (there is a spring under cover) and carefully lift out element; it may require gentle prising out, discard safely (fig 6.20).
- 3 Fit a new filter element to correct specification and replace cover and spring.

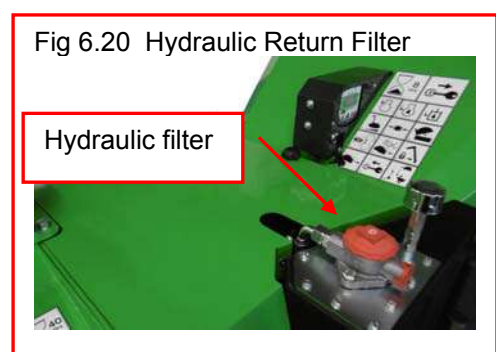

 **CAUTION!** Do not overtighten.

6.21 Hydraulic Oil change

1000 hours

Remove hydraulic oil with suction pump at filter/filler and replace with new oil and filter of correct specification.

Replace suction filter.

Dispose of waste oil according to local authority environmental procedures.

6.22 Fuses and No Stress system

There are two fuses.

A 40 amp in-line fuse protects engine pre-heat and start circuit.

A 20 amp fuse protects No Stress Power Protection System.

Note Operating speeds for No Stress system are factory set for particular machine builds and must not be readjusted.

6.23 Fault finding

Fault	Check	Action	Page
Engine will not start	Battery	Recharge	6-7
	Fuel	Fill tank	6-4
	Oil pressure	Check Oil level	6-4
	Thermal cut-out	Check operation	6-4
	Fuses	Check	6-9
Engine not at correct speed	Engine control	Check operation	5-2
	Drive belts	Replace	6-6
Feed rollers do not turn	Stop bar	Reset and check	3-2
	Chip/Track switch	Select 'Chip'	5-2
	Hydraulics	Check solenoid valve	
Feed will not reverse	Stop bar	Reset and check	3-2
	Hydraulic valve	Check operation	
Discharge does not flow	Discharge chute	Check for blockage	5-3
	Chipper flywheel	Check for blockage	5-3
Unusual noise(s)	Chipper flywheel and bearings	Check and replace	5-3 6-8

6.24 Chipper Disc Blade Re-grinding

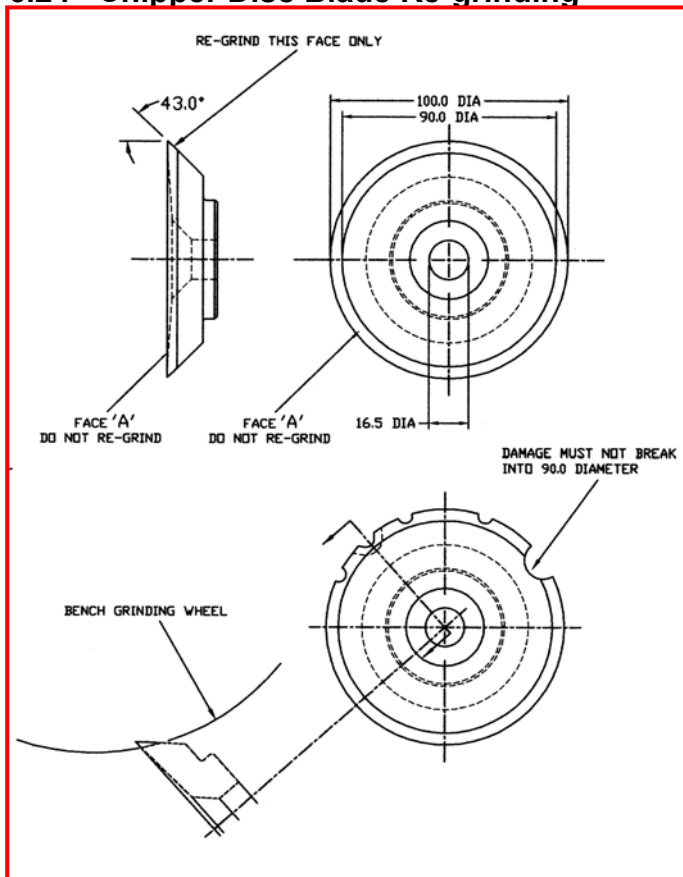

Examine set of chipper disc blades for damage. If front face 'A' is worn, blade must be scrapped. If chips have broken off cutting edge they can be re-dressed provided that they do not go inside 90mm diameter area.

Always regrind worst damaged blade first, as this will establish target weight for remaining blades.

If large chips exist over less than 30% of circumference, blade may be re-ground provided large damaged area is not used for chipping.

Chips may be repaired by grinding a cutting edge around damaged area using a bench grinder.

With chipper blade mounted on a mandrel re-grind remainder of cutting edge at 43° as shown

Re-grind in increments of approximately 0.01mm (0.004") until sharp edge is restored.

Re-grind in increments of approximately

If re-grinding breaks into 90mm diameter area, blade must be scrapped.

After re-grinding weight of blades within a set must not vary by more than +/- 1gm (0.03oz). Weight of each blade must not be less than 560gm (20oz)

Note: Disc Blades (and optional Duo blades) use a patent Nord-Lock washer pair together with a thinner Nyloc type locking nut at an increased torque setting of 200Nm.

See fig 6.7.3 and Fig 6.7.4.

Ensure that both washers are assembled as a pair with faces of fewer teeth facing each other (fig 4). Thread lubricant is recommended to ensure even torque. Do not use thread adhesive (e.g. Loctite).

Reuse:

Nord-Lock washers can normally be re-used when cleaned and re-lubricated.

Nyloc nuts should always be inspected for damage before reuse.

7.1 Storage

Thoroughly clean machine and note any replacement parts required.

Carry out 250 hour service if not already done. Refer to Section 6

Fit replacement parts when available.

Remove battery (where fitted)

Refer to 6.13

Drain fuel (engine models)

If machine is to be stored for more than 3 months, place on axle stands to remove weight from wheels*.

7.2 Removal from Storage

Charge battery and refit

Refer to 6.13

Check tyre pressures*

Refer to 6.14

Check brake operation*

Refer to 6.15

Carry out machine preparation as necessary

Refer to Section 4

*If applicable

8 Disposal

When machine is finally scrapped, the following items should be disposed of only at authorised waste disposal facilities.

Engine oil. Hydraulic oil. Antifreeze. Battery. Tyres Tracks (as applicable).

If in doubt, consult Local Authority environmental department.

Major non-ferrous items such as covers and hydraulic hoses may also be disposed of separately.

WARRANTY POLICY

PERIOD OF WARRANTY

All new machinery is supplied with a 3 year parts and labour warranty from original date of purchase.

LIMITATIONS

This warranty applies only to manufacturing defect and **does not** cover repairs or costs due to:

1. Normal wear and tear.
2. Routine maintenance or adjustment.
3. Damage caused by improper handling/abuse/misuse or neglect.
4. Lack of or over lubrication
5. Overheating due to lack of maintenance.
6. Damage due to fittings/fasteners becoming loose/detached through lack of maintenance.
7. Damage caused by cleaning with water.
8. Machines serviced or repaired by non-authorized GreenMech dealers.
9. Machines incorrectly assembled or adjusted.
10. Damage caused by improper use of the machine.
11. Items/parts that are not normally covered by the warranty, including but not limited to: Blade and Blade Assemblies - Belts - Filters - Clutch Assemblies - Lubricants - Wheels & Tyres - Axles - Batteries - Bearings - Dampers - Paint
12. Consequential loss, damages or costs.

MAINTENANCE

Maintenance carried out during the warranty period should be carried out as per section 6 of the machine owner's manual and by an authorised GreenMech dealer.

ENGINES

This is covered by the manufacturer of the engine. Please refer to the separate warranty conditions as supplied with the owner's manual.

All warranty repairs must be carried out by an authorised GreenMech dealer, except for engines, please refer to separate warranty terms supplied with the engine owner's manual.





ENGINE - 2 YEAR/2000HOUR WARRANTY AGREEMENT TERMS, CONDITIONS AND EXCLUSIONS ALL ENGINE MODELS

Kubota (UK) Limited (The Company) guarantees all products supplied by them against any defect in material, manufacture and assembly. Each of the Company's Dealers (The Supplier) is required to give the benefit of the above warranty to the RETAIL PURCHASER of the new goods supplied by the Company as follows;

The warranty period as detailed below will commence from the date of product installation.

The product should be registered for warranty on K-net by the Supplier prior to delivery and the resulting "Warranty & Installation Certificate" printed twice in readiness for completion with the Purchaser on the day of product installation.

During product installation these warranty terms and conditions should be carefully explained to the Purchaser by the Supplier, after which both copies of the "Warranty & Installation Certificate" should be signed by the Purchaser indicating their acceptance of the products installation and warranty agreement. The Supplier's representative installing the product should then acknowledge the Purchaser's agreement and signature by counter signing both copies of the "Warranty & Installation Certificate". The first copy of the "Warranty & Installation Certificate" should be retained by the purchaser and the second copy to be retained by the dealer and attached to the PDI record and safely filed for future reference and inspection by Kubota UK Limited.

This Kubota warranty agreement may be invalidated where the following has been found to apply:

- a) Where the product has been used to unreasonably perform tasks that demand more than the design and strength limitation.
- b) The product has undergone modifications not approved by Kubota.
- c) Conditions of usage can be determined to be abnormal.
- d) Normal maintenance has not been completed correctly in accordance with the manufacturer's requirements as detailed in the machines operator manual.
- e) No liability is accepted by Kubota in respect of machine or component failure when it can be determined that such failure was the result of using equipment with one or more attachments not given prior application approval by them.

A warranty in respect of any spare or replacement part (whether supplied by Kubota following a sale or pursuant to a Warranty claim) is covered to the greater of the following periods: (Parts & Labour costs)

- a) One year from the date that the part was purchased. Labour will only be covered if the part has been fitted by an authorised Kubota Dealership. Only genuine Kubota parts can be claimed for in any parts warranty claim.
- b) The remainder of the warranty period which is applicable to the product into which the part is incorporated.

GENERAL CONDITIONS

It should be noted that normal maintenance services such as belt or operational adjustments and the supply of materials used in any such service, are not covered by the terms of the Warranty.

In no event will the user be entitled to recover under this Warranty for incidental or consequential damages, including, but not limited to inconvenience, rental or replacement equipment, loss of profit or other commercial loss.

Only authorised Kubota Dealers can offer you the protection afforded by your Warranty and where possible you should request the assistance of the original Supplier to carry out repairs.

If, however you move to another area or your machine is working temporarily at some distance from the Supplier from whom it was purchased, you are recommended to obtain from the original Supplier the name and address of the Kubota Dealer nearest to your location and ask for arrangements to be made for any Warranty repairs to be carried out by them.

In the case of making a claim under this warranty, the procedure to adopt is as follows;

- a) Notify the Kubota Dealer from whom you obtained the equipment within 24 hours of failure or as soon as practicably possible. The product should not be used further if other consequential damage could occur or if a safety concern exists.
- b) Make the product available for inspection by a Dealer Technician.
- c) Make all maintenance records or similar evidence available for inspection by the Kubota Dealer to demonstrate that the product has been maintained correctly according to the operator's manual schedule using the correct Kubota lubricant.
- d) If the product/component has been dismantled or tampered with prior to the Dealer technician's inspection, warranty may be void.
- e) Any replacement parts being claimed for must be genuine Kubota parts.

Please note that lubricant, fuel and coolant samples are frequently needed to determine the cause of failure and therefore the machine should be presented with all the original fluids and their levels unchanged and undiluted

If the failure is found to be the result of faulty manufacture or assembly the failed components will be replaced entirely free of charge. Kubota Dealers are requested to submit their warranty claim upon Kubota within 28 days and return any defective parts and fluid samples immediately if requested.

In accordance with the Company policy of continuous improvements to its products, alteration in specification may be made at any time without notice and the Company shall not accept responsibility for any discrepancies which may occur between the specification of its products and the description thereof in its publications.

WARRANTY PERIOD

The full and maximum warranty term will be two years or two thousand hours whichever comes first and is subject to the exclusions shown below;

EXCLUSIONS applicable to the first year or up to 1000hrs use;

Includes all serviceable items and any component subject to fair wear and tear, such as;

Filters (air, fuel, hydraulic)	Fan belts,
Glow plugs	Fuses
Lubricants and antifreeze +	Fuel Injection Equipment*

- + Lubricants and Coolants will be accepted if lost or contaminated as a consequence of a warrantable failure and repair. Only the specified Kubota lubricants should be used and will be accepted.
- * Injection equipment warranty claim will only be accepted if supported by a written report from a Bosch or Denso Diesel Agent that clearly identifies the warrantable defect.

ADDITIONAL EXCLUSIONS in second year or after first 1000 operational hours whichever occurs first:

Radiator	Paintwork
Thermostat	Electrical components
Water pump	Hoses and pipes

This guarantee is given in addition to any rights you may have against Kubota (UK) Ltd, or the Supplier from whom you purchased the product, and does not affect or prejudice any rights you may have under the Sale of Goods Act, or in general.

**Safety Guides and Checklist as
Transcribed from and Advised by
Arboriculture & Forestry Advisory Group
and Issued as Leaflet AFA604(rev1) by
HSE, issued 04/14**

INTRODUCTION

This leaflet covers the safe working practices to be followed when operating a wood chipper.

It does not cover a combination of machines working within each other's risk zones (see AFAG leaflet 605 *Mechanical roadside processing*)

You can use this leaflet, along with the manufacturer's handbook, as part of the risk assessment process to help identify the controls to put in place when using a wood chipper.

You must also assess the effect of the site and the weather as well as following this guidance

All operators must have had appropriate training in how to operate the machine and how to carry out the tasks require (see AFAG leaflet 805 *Training and certification*)

PERSONAL PROTECTIVE EQUIPMENT (PPE)

1. Use the following PPE
 - A Safety Helmet, complying with EN 397, if identified as required in the risk assessment.
 - Eye Protection (a mesh visor complying with EN1731 or safety glasses to EN166)
 - Hearing protection (complying with EN352) where noise level exceeds 85 dB(A) (see HSE pocket card INDG363 *Protect your hearing or lose it!*)
 - Gloves with long, close-fitting cuffs that can be tucked into sleeves

- Safety Boots with good grip and ankle support (complying with EN345-1)
- Non-Snag Outer Clothing appropriate to prevailing weather conditions. High-visibility clothing (complying with EN471) should be worn when the risk assessment identifies that it is needed.

2. Each person should carry a personal first-aid kit including a large wound dressing (see HSE leaflet INDG214 *first aid at work; Your questions answered*).
3. Hand cleaning material such as waterless skin cleanser or soap, water and paper towel should be readily available.

THE MACHINE

4. Before working with a machine, check it has been properly converted from any transport mode.
5. Ensure guards for dangerous parts (e.g. belts, pulleys, shafts etc) are secure and undamaged.
6. Ensure protective devices, such as the infeed control bar (incorporating the stopping device), are working correctly (see HSE leaflet AI S 38 *Power-fed mobile wood chippers: Operator protection at infeed chutes*).
7. Ensure any lock for the chipping components has been disengaged;
8. Ensure the infeed hopper is clear of any materials.
9. Ensure Noise warning signs are in place.
10. For machines driven by a power take-off (PTO) shaft, before starting ensure:

- The PTO shaft is fitted with a suitable guard complying with EN1152, that encloses the shaft along its full length from tractor to machine.
- The guard is correctly fitted and in effective working order see AIS40 ***Power take-offs and power take-off drive shafts;***
- The PTO speed is suitable for the machine.

SELECTING THE WORK AREA

11. Select as firm a surface as possible and stabilise the machine
12. Ensure ventilation is adequate and any exhaust fumes are vented into open air if working in an enclosed space.
13. Where appropriate, if the chipper is detached from the tow vehicle, apply the handbrake and, if necessary, chock the wheels.
14. On all reasonably foreseeable approaches to the worksite, erect warning and prohibition signs conforming to the Health and Safety (Safety Signs and Signals) Regulations 1996, indicating a hazardous worksite and that unauthorised access is prohibited. In areas of very high public access, a risk assessment may indicate that additional controls (e.g. barrier tape, barriers, extra manning) are required.
15. Ensure all operations near to highways are adequately signed with the appropriate notices as specified in the DTLR Code of practice ***Safety at street works and road work (available from The Stationary Office ISBN 0 11 551958 0).***
16. Ensure that the discharge chute is positioned to prevent chips being blown onto the highway during roadside operations, or in any direction where they can affect colleagues or members of the public.

17. Position the chipper so that operators do not have to stand on embankments/slopes when feeding material into the machine

EMERGENCY PROCEDURES

18. Ensure a designated and responsible person knows the daily work programme and agree with them a suitable emergency contact procedure. Where reasonably practicable use a mobile phone or radio and pre-arrange call-in system.
19. Ensure the operators can provide the emergency services with enough detail for them to be found in the event of an accident, e.g. the grid reference, the distance from the main road, the type of access (suitable for car/four-wheel drive/emergency service vehicles). In urban areas street names are essential. Know the location details before they are needed in an emergency. (Also see AFAG leaflet 802 Emergency Planning)

OPERATION

20. Make sure the cuffs of gloves are close fitting or tucked into you're sleeves to stop them being caught on material as it is fed into the chipper.
21. Set the engine speed (and set the stress control if fitted) to obtain optimum performance.
22. Check that material to be chipped is free from stones, metal and foreign objects.
23. Stand to one side of the infeed rollers to avoid being hit by ejected material.
24. Let material go as soon as it is engaged in the infeed rollers or chipping components.

25. Use a push stick at least 1.5 metre long, for both short produce and for the last piece of produce to be chipped.
26. Do not put any part of your body (including hands or feet), into the infeed hopper while the machine is running.
27. Always follow the manufactures' instructions for dealing with blockages on the machine.
28. Keep the area of ground in front of the infeed hopper free from debris to prevent any tripping hazard.
29. Remove the engine start key when the machine is left unattended or when undertaking any maintenance.

FUELLING

30. Stop engine and, if necessary allow the machine to cool before refuelling.
31. Petrol vapour is invisible and can flow considerable distances from spillage or fuelling sites. Maintain a safe distance from any source of ignition at all times.
32. Store fuel to avoid vapour ignition from any source such as fires, people smoking or the wood chipper. Select a site shaded from direct sunlight and away from watercourses and drains.
33. Containers must be clearly labelled and have securely fitting caps. Plastic containers must be designed and approved for use with petrol or diesel fuel.
34. Replace the fuel cap securely.
35. Keep fuel from contacting the skin. If fuel gets into the eyes wash out with sterile water immediately and seek medical advise

Maintenance

36. Ensure the machine is carried out in accordance with the manufacture's handbook.
37. Check chipping components and knives each day for damage and wear.
38. Wear gloves when handling knives.
39. Before working on knives, confirm that the engine is switched off, the start key removed, and the chipping component is stationary.
40. Before opening any guard/cover or reaching into the infeed hopper or discharge chutes make sure that the engine is switched off, start key removed and dangerous parts have come to a stand still.
41. Knives must be changed or reversed if damaged or blunt. Knives must be scrapped when worn to the minimum size specified by the manufacturer.
42. When new/sharpened knives are fitted, ensure that there is the recommended clearance between the knives and the anvil.

MOVING THE MACHINE

43. Stop the engine and remove the start/stop key.
44. Lock the chipping components.
45. Secure the infeed hopper and the chip discharge chute in the transport position.
46. Check the towing bracket, attach, then lift and secure the jockey wheel.
47. Connect the electrics and the safety chain/s to the towing vehicle.

Page 3

48. Ensure that the load is secure and that people are in a safe position before moving off.

Further Reading

Noise: Don't lose your hearing!

INDG363(rev2)

HSE Books 2012

www.hse.gov.uk/pubns/indg363.htm

First aid at work: Your questions answered

Leaflet INDG2114(rev1)

HSE books 2009

www.hse.gov.uk/pubns/indg214.htm

Safety signs and signals. The Health and Safety (Safety Signs and Signals) Regulations 1996. Guidance on Regulations L64 (Second edition) HSE Books 2009 ISBN 978 0 7176 6359 0

www.hse.gov.uk/pubns/books/l64.htm

Power-fed mobile wood chippers: Operator protection at infeed chutes AIS38 HSE 2013

www.hse.gov.uk/pubns/ais38.htm

Power take-offs and power take-off drive shafts AIS40 HSE Books2012

www.hse.gov.uk/pubns/ais40.htm

Treework webpages:

www.hse.gov.uk/treework

Risk Assessment

Assessment No: G001



Company Name: **GreenMech Ltd**

Activity: ARB Trak 150

Hazard	At Risk	Consequence (C)		Likelihood (L)		Risk Score	Controls	Revised		Final Risk Score
	Those likely to be affected	Likely injury from hazard	Rating	Of incident	Rating			C Rating	L Rating	
ENTANGLEMENT With cutter in base of CHIPPER infeed chute	OPERATOR	FATALITY – LOSS OF LIMB	5	VERY LIKELY	5	25	Reach area safety distance to cutter complies to latest HSE guidelines. Fix safety stop rail to upper and side perimeter on infeed chute. Operation of this emergency stop system should operate as recommended by HSE. Only appointed operators to use machine (competent)	5	2	10
STABBING AND PUNCTURE by projectiles from cutter. Wood, stones, nails rebounding back out of infeed chute	OPERATOR	Injuries to face, eyes, head and hands	3	PROBABLE	4	12	Trained Operator. Check only green waste is fed into machine. Safety helmet to BSEN 397 Forestry visor Hard wearing gloves	3	2	6

Key:

Consequence	Score	Likelihood	Score	To find risk Score multiply consequence rating by the likelihood rating
Fatality	5	Very likely	5	Final revised risk score acceptable to the company is 10 or less. If higher, further controls are required.
Disability	4	Probable	4	
Very serious (broken limbs)	3	Possible	3	
Important (3 day accident)	2	Remotely possible	2	Final revised likelihood score must be 2 or less
Noticeable (first aid)	1	Improbable	1	

Signed:
Date:
Review Date:

Risk Assessment

Assessment No: G001-2



Company Name: **GreenMech Ltd**

Activity: ARB Trak 150

Hazard	At Risk	Consequence (C)		Likelihood (L)		Risk Score	Controls	Revised		Final Risk Score
	Those likely to be affected	Likely injury from hazard	Rating	Of incident	Rating			C Rating	L Rating	
NOISE Guaranteed sound pressure level of Lwa 120dB	OPERATOR	NOISE INDUCED HEARING LOSS	4	PROBABLE	4	16	Wear hearing protection to BE EN 352-3. Display mandatory 'wear hearing protection' sign	4	2	8
	THIRD PARTY									
VIBRATION – movement of machine	OPERATOR	BROKEN OR BRUISED LIMB	3	POSSIBLE	3	9	Trained Operator. Position machine on sound ground, if on slope must be across the slope and less than 35° and no possibility of land slip.	3	2	6
STABBING – PUNCTURE When operating handle to raise engine – residue from exhaust chute	OPERATOR	EYE INJURIES CUTS TO FACE	2	POSSIBLE	3	6	Cordon off collection point. Operator to wear head and face protection	2	1	2
	THIRD PARTY									

Key:

Consequence	Score	Likelihood	Score	To find risk Score multiply consequence rating by the likelihood rating
Fatality	5	Very likely	5	Final revised risk score acceptable to the company is 10 or less. If higher, further controls are required.
Disability	4	Probable	4	
Very serious (broken limbs)	3	Possible	3	
Important (3 day accident)	2	Remotely possible	2	Final revised likelihood score must be 2 or less
Noticeable (first aid)	1	Improbable	1	

Signed:

Date:

Review Date:

Risk Assessment

Assessment No: G001-3



Company Name: **GreenMech Ltd**

Activity: Arb Trak 150

Hazard	At Risk	Consequence (C)		Likelihood (L)		Risk Score	Controls	Revised		Final Risk Score
	Those likely to be affected	Likely injury from hazard	Rating	Of incident	Rating			C Rating	L Rating	
ENTANGLEMENT Branches with clothing	OPERATOR	Drawn into cutters – FATALITY – LOSS OF LIMBS	5	POSSIBLE	3	15	Wear snug fitting clothes. No ties, scarves etc. Same controls as for previous hazard of entanglement with cutters. Wear gloves with long cuffs which can be tucked into sleeves	5	2	10
STABBING AND PUNCTURE – Processed green waste	OPERATOR THIRD PARTY	EYE INJURIES, CUTS TO FACE	1	POSSIBLE	3	3	Trained operator Lock off exhaust chute Cordon off collection point	1	1	1
STABBING AND PUNCTURE – Handling branches	OPERATOR	CUTS TO HANDS	2	QUITE POSSIBLE	4	8	Wear hardwearing gloves with long cuffs that can be tucked into sleeves.	2	2	4

Key:

Consequence	Score	Likelihood	Score	To find risk Score multiply consequence rating by the likelihood rating
Fatality	5	Very likely	5	
Disability	4	Probable	4	
Very serious (broken limbs)	3	Possible	3	
Important (3 day accident)	2	Remotely possible	2	
Noticeable (first aid)	1	Improbable	1	Final revised likelihood score must be 2 or less

Signed:
Date:
Review Date:

Risk Assessment

Assessment No: G001-4



Company Name: **GreenMech Ltd**

Activity: ARB Trak 150

Hazard	At Risk	Consequence (C)		Likelihood (L)		Risk Score	Controls	Revised		Final Risk Score
	Those likely to be affected	Likely injury from hazard	Rating	Of incident	Rating			C Rating	L Rating	
IMPACT Being struck by branch when feeding green waste into cutters	OPERATOR	BROKEN LIMB BRUISES	3	POSSIBLE	3	9	Stand at side of machine. Trained operator	3	2	6
CRUSH, IMPACT Being caught between tracks when opening or closing	OPERATOR	BROKEN LIMB, BRUISES	3	POSSIBLE	3	9	Trained operator. Keep other persons away from machine. Out feed chute must be pointed to rear of machine	3	2	6
MANUAL HANDLING Lowering outfeed chute	THIRD PARTY	Back problems. Damaged tendons, muscles etc	3	POSSIBLE	3	9	Trained operator. Keep other persons away from machine. Out feed chute must be pointed to rear of machine.	3	1	3

Key:

Consequence	Score	Likelihood	Score	To find risk Score multiply consequence rating by the likelihood rating
Fatality	5	Very likely	5	
Disability	4	Probable	4	
Very serious (broken limbs)	3	Possible	3	
Important (3 day accident)	2	Remotely possible	2	
Noticeable (first aid)	1	Improbable	1	Final revised likelihood score must be 2 or less

Signed:
Date:
Review Date:

Risk Assessment

Assessment No: G001-5



Company Name: **GreenMech Ltd**

Activity: ARB Trak 150

Hazard	At Risk	Consequence (C)		Likelihood (L)		Risk Score	Controls	Revised		Final Risk Score
	Those likely to be affected	Likely injury from hazard	Rating	Of incident	Rating			C Rating	L Rating	
EJECTION, PENETRATION Failure of hydraulic system	OPERATOR	Penetration of skin. Bruising. Face injuries.	3	POSSIBLE	3	9	Trained operator. Cutters isolated from power source whilst machine in motion. Very slow speed. Plan and inspect safety of route to work place.	3	1	3
	THIRD PARTY									
FALLING FROM STAND-ON PLATFORM WHEN IN MOTION	OPERATOR	Spinal or broken limb	3	POSSIBLE	3	9	Trained operator. Very slow speed. Plan and inspect Safety of route to work place.			

Key:

Consequence	Score	Likelihood	Score	To find risk Score multiply consequence rating by the likelihood rating
Fatality	5	Very likely	5	
Disability	4	Probable	4	
Very serious (broken limbs)	3	Possible	3	
Important (3 day accident)	2	Remotely possible	2	
Noticeable (first aid)	1	Improbable	1	Final revised likelihood score must be 2 or less

Signed:
Date:
Review Date:

Measurement Information

Date of Measurement 18/08/2012 **Measurement made by:** JAET
Equipment under test: Greenmech ARB Trak 150

Measurement Equipment

Sound Level Meter CEL-440 **Manufacturer** Casella **Date of last verification** 08/22/03
Acoustic Calibrator Type CEL_282 **Manufacturer** Casella **Date of last verification** 08/22/03
Calibration Level 114dB

Measurement Setup

Number of Measurements N 6
Radius of Measurement Area r 4 m
Surface Area S 100.53 m²
Reference Surface Area S₀ 1 m²
Directivity Index DI 0 dB

Calculated Data

Calculated Data Duration
Broadband Sound Power dB(A) **115** Lw dB(A) 00:00:20 hh:mm:ss



GreenMech
The Professionals' Choice

GreenMech Ltd • The Mill Industrial Park • Kings Coughton • Alcester • Warwickshire • B49 5QG • UK
Tel: 01789 400 044 • Email: sales@greenmech.co.uk • Web: www.greenmech.co.uk