

**EVO 205<sub>D</sub>**



**OPERATOR'S MANUAL >>>**

[www.greenmech.co.uk](http://www.greenmech.co.uk)

**INTRODUCTION**

This manual explains the proper operation of your machine. Read these instructions thoroughly before operating and maintaining the machine. Failure to do so could result in personal injury or equipment damage. Consult your GreenMech supplier if you do not understand the instructions in this manual.



**CAUTION!** This symbol indicates important safety messages in this manual. When you see this symbol, be alert to the possibility of injury to yourself or others, and carefully read the message that follows.

Keep this manual in the box provided and treat as part of the machine. Locate and note here the serial number and quote it in any communications. This is important when ordering spares. Remember to include all numbers and letters.



**VIN Number**.....

**Serial Number**.....

**Write in the number!**

This manual covers the following models.

**Evo205D trailed Road-Tow chipper, diesel engine (stage 5), Smart-Sense controller**

The information in this manual is correct at the time of publication. However, in the course of development, changes to machine specifications are inevitable. Should you find any information to vary from the machine in your possession please contact your GreenMech dealer for up to date information.

This manual may contain standard and optional features and is not to be used as a machine specification.

**PURPOSE**



**CAUTION!** This machine is designed solely to chip wood and must not be used for any other purpose. The machine should only be used by trained operators who are familiar with the content of this instruction manual. It is potentially hazardous to fit or use any parts other than genuine GreenMech parts. The company disclaims all liability for the consequences of such use, which in addition voids the machine warranty.

Fig 2.1 EVO205D Road-Tow Main Features

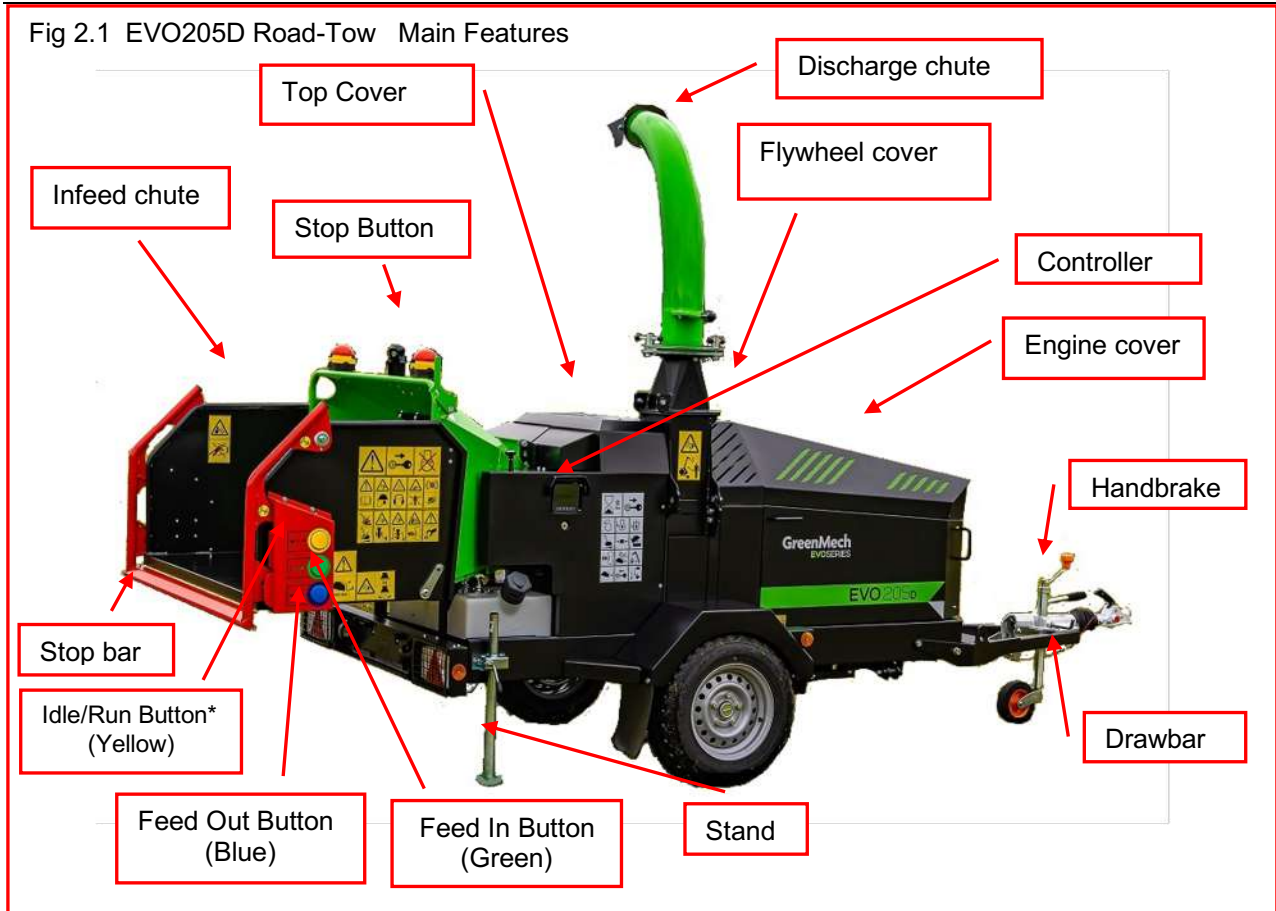

TECHNICAL SPECIFICATIONS EVO205D model	
	EVO205D Road Tow
Infeed Throat aperture	205mm X 270mm
Max Timber Dia	205mm
Throughput	22cu.mt/hr
Power Unit	Kubota Diesel 1803-CR-TE4B 50HP 1826cc
Infeed Chute	1250mm x 700mm
Chipping Blades	6 disc blades
Flywheel Speed	1450 rpm
Feed Rollers	2 x Hydraulic
Power Control	Smart-Sense No-Stress Electronic Feed Roller Controller
Fuel Capacity	33Lt diesel
Tyre size	18570//R13
Tonnes per Hour	4.25 tonne/hr
Discharge rotation	280 deg.
Hydraulic capacity	33Lt
Length	4000
Width (working)	1600mm
Width (transport)	1600mm
Height (Work)	2760mm
Weight	1450kg
Sound Power Lwa	114dB(A)
Sound Pressure LPa	91dB(A)

**Noise**

Noise levels vary depending on type of material being processed. Also duration of operation is variable. Noise emission tests have been carried out and the guaranteed sound power level (**Lwa**) is displayed on a decal as follows:

**Evo205D– 114dB(A)**

Minimise noise and fuel consumption by activating Economy Mode on controller (Section 4.6), switching from Run to Idle, or stopping the engine whenever chipping is not in progress.



**CAUTION!** Operators must wear appropriate ear protection. Bystanders must be kept away from proximity of machine.

**Lifting Points**

There is a single central lifting point by the base of the discharge chute.



**CAUTION!** Lift with extreme care. The machine may tilt because the single lifting point may not be directly over the centre of gravity.

**Drawbar and hitch**

Ball type hitch with overrun brake and safety cable.



**CAUTION!** Ensure that the towing vehicle is correctly suited to the trailer weight and drawbar (nose) loading. If necessary check with national vehicle legislation.

**ENSURE! :**

All Operators must be fully trained in the use of their machine.  
(*Certificated Operator training courses are available on request.*)  
Operator Manual is read and understood.  
Enclosed HSE guidance notes are read and understood.  
Appropriate Personal Protective Equipment (PPE) is worn, including non-snag clothing, gloves, eye and hearing protection.  
Machine is positioned on level ground and machine is level with infeed chute at not less than 600mm (23.62 inches) above ground level (fig 3.4.3).  
Handbrake is applied and if necessary, wheels are chocked, when machine is detached from towing vehicle.  
All guards are fitted and in good condition.  
Blades are in good condition and secure.  
All blades are sharpened or replaced in "Sets".  
All fasteners are checked regularly for tightness.  
Only "WOODEN" materials free of nails etc., are fed into machine.  
Correct First Aid Kit including large wound dressing is available on site.  
Fire extinguisher is available on site.

**NEVER! :**

Work on machine until chipper flywheel is stationary and engine or PTO has stopped.  
Operate machine without protective clothing (Eye protection, Earmuffs, and Gloves), or high visibility clothing when working on roadside.  
Operate with loose articles of clothing, including loose cuffs on gloves.  
Work under a raised component without adequate safety support.  
Operate machine with untrained personnel or with individuals present who are not involved in chipping work operation.  
Leave machine unattended with engine running at full operating speed. (See section 4)  
Put any part of your body into infeed chute while machine is running.  
Operate machine whilst under the influence of alcohol or drugs.  
Operate machine inside a building or confined space.  
Climb on infeed chute.  
Impede or obstruct Stop control.

**ALWAYS! :**

Check machine before starting (see Section 4 Preparation and Section 5.1 Operation: Pre-work checks).  
Be aware of potential hazards in work area, i.e. uneven ground, tree roots, trip/slip hazards, obstructions and type of materials being fed into machine.  
Feed from a side.  
Keep clear of discharge area.  
Have a second trained operator within easy reach of machine.  
Maintain strict discipline at all times.  
Service machine at specified periods. (see Section 6: Routine Maintenance).  
Note direction of discharge chute and if necessary, note wind direction to prevent debris from being blown into highway or where it could affect members of the public.  
Keep machine level.  
Check route to worksite for gradients, undulations and obstructions.  
Remove key before doing any maintenance.

### 3.4 Safety Controls and Switches

#### 3.4.1 Emergency Stop Bar and buttons (fig 3.4.1)

In the event of an emergency, push stop bar right in or press stop button to STOP feed rollers.

Once the emergency has been rectified, pull Red stop button back up if down.

Press Green button to restart rollers to continue Feed In, or press and hold Blue button to Feed Out to eject material. Stop bar returns to work position but does not restart feed rollers.

If stop be tripped accidentally in normal working conditions, i.e. NOT an emergency, then Feed In can be recovered by pressing Green button, having first checked stop bar is free to move and stop buttons are up in work position.

To reverse feed rollers (Feed Out) press and hold Blue button. To regain Feed In press Green button.

#### 3.4.2 Engine Stop (fig 3.4.2).

To stop engine turn key anticlockwise to '0' position.

To restart, turn key clockwise to Start.

To disable machine, remove key.

Fig 3.4.1 Control Bar and Reset button

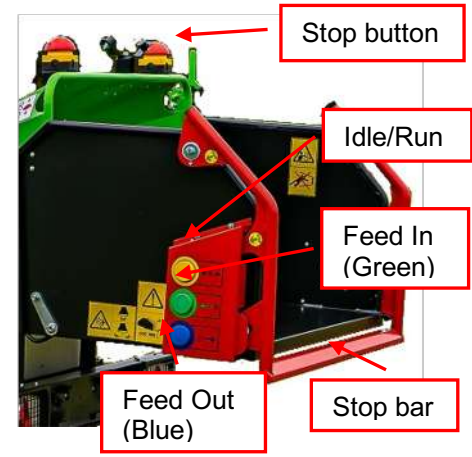

**CAUTION!** Do not restart engine until hazard has been removed.

Fig 3.4.2 Engine Stop/Start

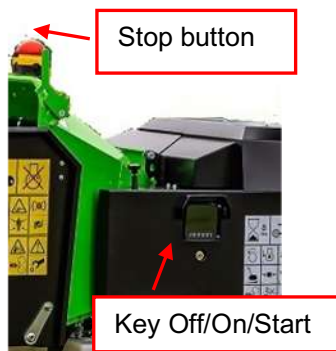
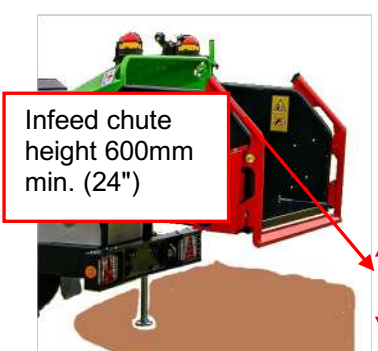

Fig 3.4.3 Infeed chute height



### 3.5 Control cut-outs

Cut-out switch under engine cover prevents starting with covers removed.

Engine overheating is protected by thermal cut-out switch in coolant circuit.

Low engine oil pressure is protected by pressure switch in engine oil pump.

### 3.6 No Stress system with Smart-Sense controller

Speed sensor disables feed roller FEED IN or FEED OUT mode when engine speed is below factory pre-set value.

Overload sensor stops and restarts rollers during Feed In.

Economy Mode setting (optional) when unloaded reduces speed to idle after preset time.

Refer to Section 4.6 for further information.

### 3.7 Number not used

**3.8 SYMBOLS on the MACHINE**

These relate to operator safety, correct use and maintenance of machine. Check that all personnel understand and are familiar with meanings before using machine.

**Important Safety symbols**

Take correct action shown on display box below stated hazard box (see table)



<b>Caution!</b>		<b>Remove Key</b>		<b>Do NOT start engine</b>	
<b>Caution!</b>	Beware flying object hazard	Beware noise hazard	Beware trapping hazard	Brakes off -incorrect	
Read instruction manual	Wear helmet & visor	Wear ear protectors	Wear proper clothes	Brakes on -correct	
Machine not level -incorrect	Beware flying object hazard	Beware flying object hazard	Beware exposed drives hazard	<b>Caution!</b>	
Machine level -correct	Keep bystanders away	Position and lock discharge chute	Fit all guards	Keep nuts tight	

**Important Operating Checks Notice**

Before use carry out daily stated checks in order shown (see table)

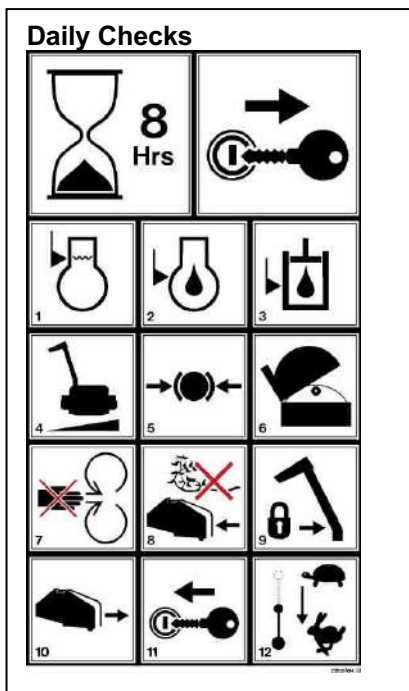

<b>Every 8 Hours – Daily checks</b>		<b>Remove key stop engine</b>	
1. Check coolant level	2. Check engine oil level	3. Check hydraulic oil level	
4. Check machine is level	5. Check brakes are on	6. Check chipper flywheel is clear of debris	
7. Check all guards are in place	8. Check infeed chute is clear of debris	9. Lock discharge chute	
10. Check stop bar	11. Start engine	12. Increase from Idle to Run	

Important Safety Information

**Caution! Beware of thrown object hazard**



**Action: Stand to side of infeed chute, NOT in centre.**

**Caution! Beware of thrown object hazard**



**Action: Keep away from fast discharge chute**

**Face shield must be worn**



**Wear face shield**

**Ear defenders must be worn**



**Wear ear protectors when operating this machine**

**Lift Point**



**Sound level (typical only)**



LWA  
**120 dB**

**Ear defenders must be worn**

**Caution!**



**Do not climb into infeed chute**

**Caution! Infeed chute trapping hazards**



**Keep hands clear. Do not climb in**

**Caution!**



**Do NOT operate with infeed chute at less than 600mm from ground (bottom stop bar).**

**Transport Lock**



**Lock this component before moving machine**

**Caution! Beware Crushing hazard!**



**Do NOT work or park directly up or down slope.**



Maintenance Information



**Radiator cleaning**

<b>8 Hours</b> Check radiator screen	<b>40 Hours</b> Blow out radiator core
---	---

**Chipper Flywheel cleaning**

<b>Caution!</b> Caution! Sharp edges	<b>Read Manual!</b> 1) Wear protective gloves	<b>Remove key</b> 2) Release cover bolts
3) Open chipper covers	4) Lock / Block flywheel	5) Clean blade nut and bolt recess
6) Remove blade nut	7) Clean blade spigot and flywheel recess	8) Replace and Tighten to 200Nm
9) Replace all covers	10) Secure covers	11) Replace key

Operating Information

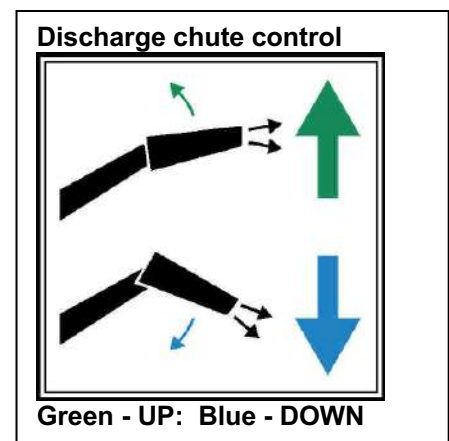
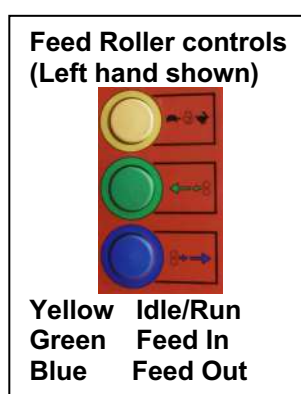
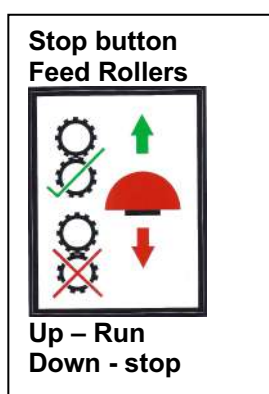

### 4.1 Initial Fuelling and Parking

Fill fuel tank with correct fuel (fig 4.1).

Top up hydraulic tank if necessary, with correct oil. See Section 6.

Position chipper on firm and level ground.

Apply vehicle handbrake.

If machine is detached from vehicle (fig 4.3), set jockey wheel clamp to allow jack screw to lift drawbar clear of vehicle hitch, apply trailer handbrake and chock wheels.

Set drawbar jockey wheel height to level machine body and set infeed chute height to minimum of 600mm.

Lower and secure rear stand.

Fig 4.1 Fuel tank

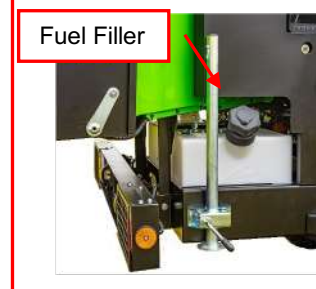

### 4.2 Infeed Chute

1) Release infeed chute catches (fig 4.2), and gently lower infeed chute to work position.

2) Check height of infeed chute for safe working height (fig 3.4.3)

Fig 4.2 Infeed Chute Catches



### 4.3 Drawbar adjustment

1) Support front of chipper with suitable jack.

2) Remove height adjustment locking bolts on each side (fig 4.3).

3) Adjust jack until chute correct safe height from ground.

4) Refit bolts in their new position and tighten securely.

5) Remove jack.

Fig 4.3 Adjustable Drawbar and Stand

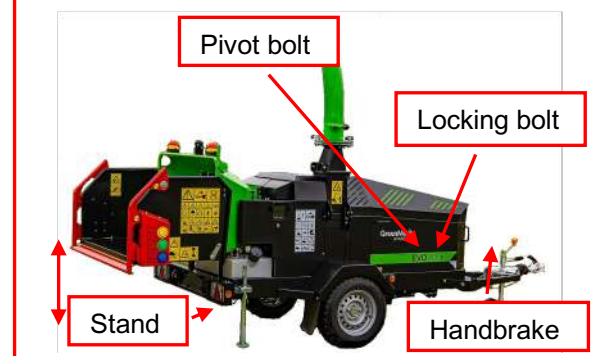

**CAUTION!** Infeed chute must not be used at less than 600mm from ground (fig 3.4.3). Adjust drawbar of Road tow models as necessary.



**CAUTION!** Before travelling, always fold up and secure infeed chute flap.

**4.4 Discharge Chute – standard (fig. 4.4)**

- 1) Release swivel clamps, point chute in desired direction away from infeed chute and tighten clamps.
- 2) Set flap at desired height and tighten clamp.

Fig 4.4. Discharge Chute

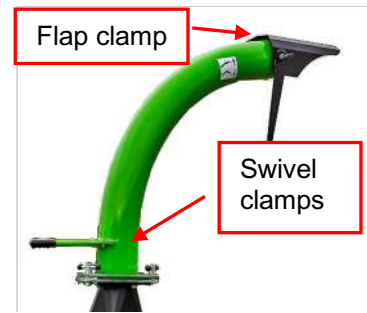

**CAUTION!** Do not point discharge chute towards infeed area.

**4.4.1 Optional folding discharge chute (Fig 4.4.1 and Fig 4.4.2)**

From storage position fold out to work position, secure hinge clamp and follow 4.4. to set direction and flap height.

Fig 4.4.1 Discharge Chute (folding option – work position)

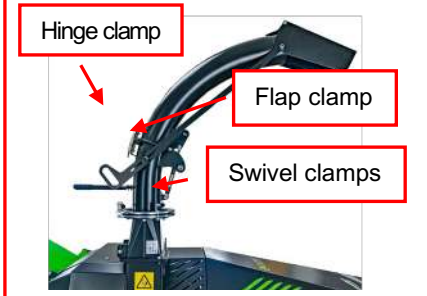

Fig 4.4.2 Discharge Chute folded



**CAUTION!** Travel with discharge chute down is not recommended, unless restraint is provided.

**4.5 Work Position (Typical)**

Typical work position (fig 4.5) shown with infeed chute down and discharge chute pointing away from infeed.

Fig 4.5 Work position (typical)

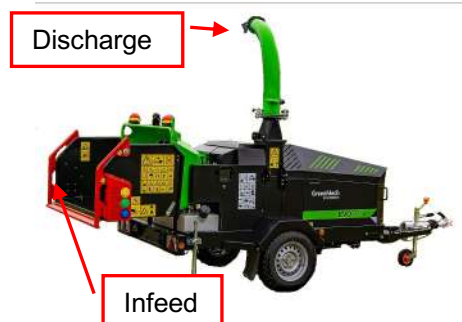

## 4.6 Smart Sense controller (fig 4.6)

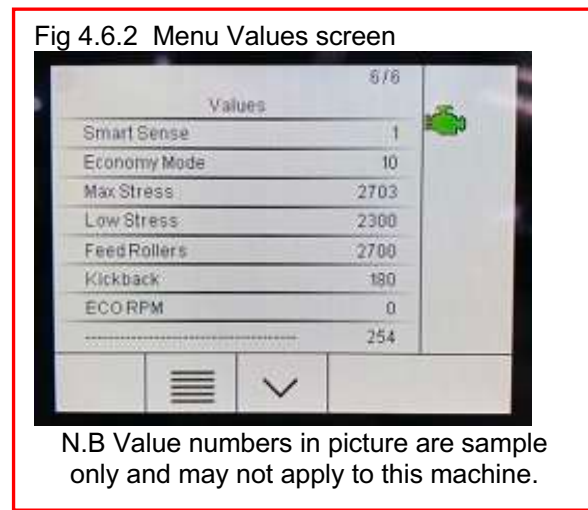
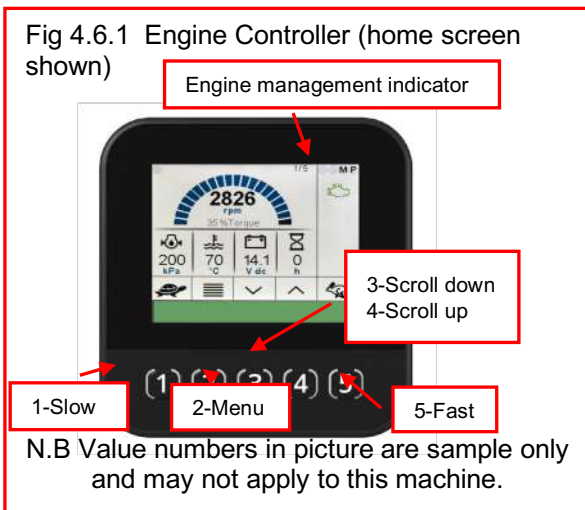

### Operator settings: ( Fig 4.6.1 Home screen, Fig 4.6.2 Values screen)

#### Screen Brightness

Press menu button (2) (fig 4.6.1) to select brightness adjustment screen, then press buttons 3 or 4 to adjust, then button 1 to return to home screen.

#### Smart Sense On or Off

Press Menu (2) to select **Value screen** (fig 4.6.2) to set control options for desired operation. Select functions to set as below, using scroll button (3).

Set **Smart-Sense** On by setting from 0 (Off) to 1 (On) to enable No-Stress feed system to function automatically. To override set to 0 (Off). Feed rollers will run at max stress speed only.

#### Economy Mode On or Off

Set **Economy Mode** On by selecting delay time in seconds from 10 to 40 before machine will automatically slow to idle after no load is detected and recovers when loading is resumed. To override set to 0 (Off) for manual operation.

#### Kickback Timer

Set **Kickback** timer number higher or lower to adjust the time before long length of material is to be kicked back by roller reversal.

#### Diesel Particulate Filter (DPF) regeneration is normally automatic

To force DPF, press menu (2) to select DPF screen and press button (1). Button (5) can be used to inhibit regeneration in a fire sensitive area (e.g. heavy woodland, fuel station).

**Engine speed** can be controlled either from Home screen using buttons (1) and (5), or yellow Idle/Run button on infeed chute. Yellow Idle/Run button switches between idle and full speed and overrides Economy Mode timer setting.

**General Note:** Maximum and minimum stress speeds, feed roller start speed and Idle (Eco) speeds are all factory set and locked. Consult dealer or Greenmech Ltd for resetting.

Values shown in Fig 4.6.1 and Fig 4.6.2 are sample and may not apply to this machine.

**5.1 Pre-Work Checks:**

Check machine is stationary, Key in OFF position or removed, and hand brake applied if separated from vehicle.

Check that machine is level and infeed chute is not less than 600mm from ground (fig 3.4.3).

Check engine oil level (See Engine instruction manual).

Check hydraulic oil level (See Section 6).

Check fasteners for tightness and hydraulic connections for leaks.

Check condition of blades as follows:

- 1) Raise engine cover. Check nothing is rotating.
- 2) Remove bolts (2) retaining chipper flywheel cover.
- 3) Using discharge chute handle as a lever, swing back cover onto stop to expose chipper flywheel and blades. (fig 5.1.1)

**CAUTION! Beware sharp edges of blades and unexpected movement.**

4) Turn flywheel to align locking pin with a mating boss (2) and release pin into boss to prevent flywheel from turning.

5) Remove any loose wood material.

6) Retract locking pin and carefully rotate chipper flywheel to check tightness of blade bolts and condition of blades (fig 5.1.2).

7) If any bolts are loose, refer to Maintenance Section 6.7 for further action.

8) Retract and turn locking pin to prevent it springing back and replace chipper flywheel cover.

9) Tighten all bolts securely.

10) Remove any loose material and dust from radiator and engine bay

11) Replace all covers and secure.

Check discharge chute is in desired position pointing away from infeed and all clamps are tight. (see Section 4.4)

Check work area and erect signs and cone off discharge area if necessary. Check **ALL** safety procedures have been followed.

Fig 5.1.1 Chipper flywheel cover

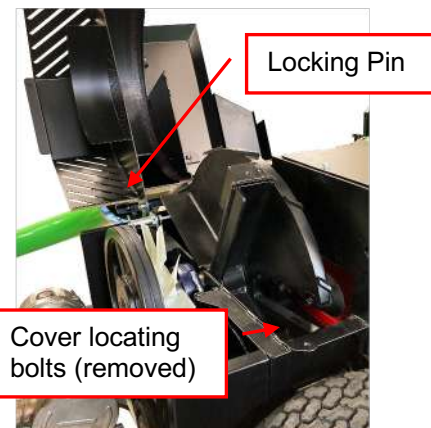
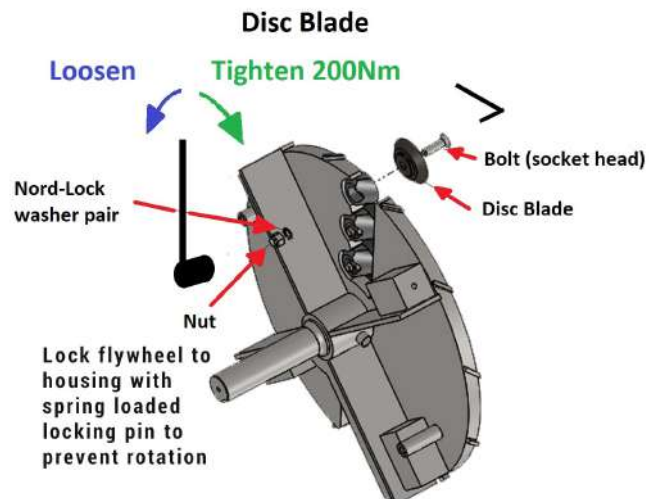

Fig 5.1.2. Flywheel and blades



**CAUTION! Always work with chipper level, preferably with the infeed direction slightly down the slope to minimise the risk of material falling back out.**

## 5.2 Starting Machine (Fig 5.2)

**Note:** Read Section 4.6 before starting.

**CAUTION!** Beware sharp edges and dust. Wear protective gloves and eye shield!

Check all other personnel are clear of machine.

Check that feed roller stop bar is free to move, and feed roller Stop buttons in Up (Run) position.

### Start engine (Fig 5.2.1 Fig 5.2.2)

- 1) Turn the ON - OFF key to position I. Wait for engine pre-glow countdown indicator to cease and chipper speed 0 rev/min to be displayed.
- 2) Turn key to START engine and start chipper.
- 3) Press yellow IDLE/RUN button or press and hold 'hare' button (5) on controller until engine reaches preset operating speed.
- 4) Press green FEED IN button when ready to start loading chipper.

Fig 5.2.1 Engine Controls

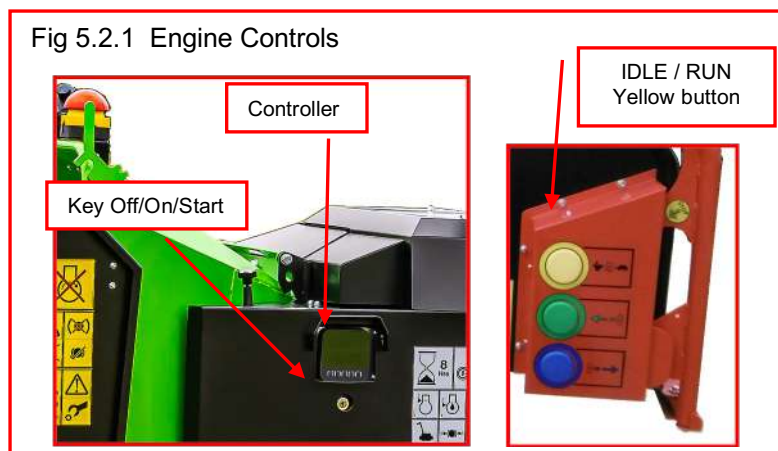
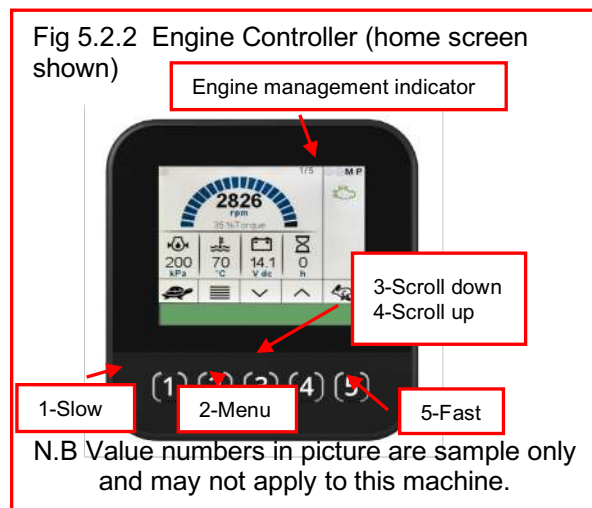

Fig 5.2.2 Engine Controller (home screen shown)



## 5.3 Stopping Machine

- 1) Push stop bar to STOP position, or press down red Stop button to stop feed rollers.
- 2) Press yellow button to IDLE or press and hold 'tortoise' button (1) on controller and allow chipper flywheel to slow down (fig 5.2).
- 3) Turn key anticlockwise to OFF (position 0) to stop engine.
- 4) Wait for chipper flywheel to stop.

**CAUTION!** Chipper flywheel will take several seconds to stop due to its inertia.

## 5.4 Blockages

Stop engine and REMOVE key to secure place.

**CAUTION!** Chipped material is inflammable. Expect large volume and prevent from falling into engine compartment. All material must be removed.

Open chipper flywheel cover. See 5.1 Pre-work checks.

Look into chamber to identify problem if possible, before reaching in.

Open discharge chute and fold down at hinge to inspect and clear. (fig 5.4.1)

Clean out discharge chute thoroughly with a suitable rod to pass around bends as necessary.

**CAUTION!** Beware sharp edges of blades and unexpected movement of flywheel due to resistance of engine. Wear protective gloves.

Check if chipper flywheel is free to rotate. Pull top of flywheel in operating direction of rotation. If so proceed to 6 below.

If flywheel does NOT rotate freely, proceed as follows:

- 1) Release roller spring tension at adjuster. (fig 5.4.2).
- 2) Using special bar provided, place in socket, pull as shown (fig 5.4.3) and twist to hook and lock roller away from fixed roller.
- 3) Inspect rollers and blades from infeed chute and carefully clear material.
- 4) Carefully remove excess loose material from around chipper flywheel and note any obstructions.
- 5) Carefully rotate chipper flywheel in reverse direction by full revolution to release blocked material. Use bar against paddle blades for aid.
- 6) Carefully remove all material, checking for obstructions. Check rotation of chipper flywheel. Check condition of blades. See 5.1.6

**Note:** Always attempt to find reason for blockage. e.g. blunt blades, slack drive belts.

6) Unhook and release lifting bar and stow.

7) Refit and tension spring adjuster under chassis

8) Re-assemble all covers with correct fasteners and check for security.

9) Start machine as 5.2 and check operation.

**Note:** If machine will not run, repeat process or contact dealer for technical advice.

Fig 5.4.1 Discharge Chute folded

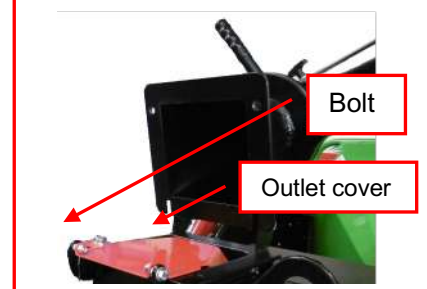
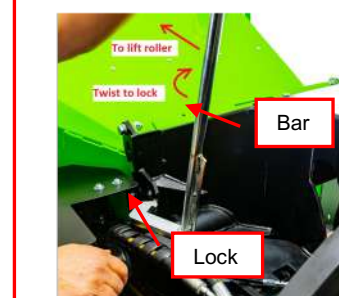

Fig 5.4.2 Feed roller spring



Fig 5.4.3 Feed roller lift



### 5.5 Number not used

### 5.6 Preparing For Transport On Completion Of Work (fig 5.6.1)

Check that engine has stopped and chipper flywheel is stationary.

Remove surplus material from infeed chute and all machine surfaces.

Fold infeed chute into transport position.

Unlock, lift and secure covers to remove debris.

Replace and secure covers.

Raise rear stand and lock securely.

If detached, re-attach trailer to vehicle, raise jockey wheel, connect safety cable and electric services.

**Note:** It is not recommended to fold discharge chute down for transport.

See Section 4.4.1 for optional folding discharge chute.

Fig 5.6.1 Transport position



### 5.7 Operating Hints

Check that chipper flywheel is at full speed, rpm readout should be above 2450 rpm.

**Note:** “No Stress” system will only allow FEED IN (Forwards) and FEED OUT operation of feed rollers when machine is running at FULL operating speed and not overloaded.

Reduce chipper speed to IDLE whilst further material is collected for chipping.

See Section 4.6 to make best use of Smart Sense controller operator settings.

Take care when feeding wood into machine to allow for awkward shapes to “KICK” when contacting feed rollers.

Position end of larger sections of wood inside infeed chute and then support other end whilst pushing wood into feed rollers.

**Note:** If chipper becomes blocked do not continue to feed. It will make removal of blockage more difficult. See 5.4.



**CAUTION!** Do not release discharge chute clamps when chipping is in progress. Elevation of discharge is altered by means of adjustable flap (fig. 4.4).



**CAUTION!** Keep working area around the machine clear at all times and check only authorised personnel are present.

### 5.8 Adjustable Feed Roller Speed Control

When chipping wood sizes larger than 150mm diameter it is necessary to reduce feed roller speed to suit material being chipped.

Turn control knob (fig 5.8) to adjust speed.

Fig 5.8 Adjustable feed roller control





**ROUTINE MAINTENANCE SCHEDULE**

**⚠ CAUTION! Always remove key and check for rotation before carrying out any maintenance.**

**Note:** Covers are bolted and only released by raising engine cover. Replace and secure all covers when task is completed.

Instructions refer to all models except where stated for specific type (e.g. Road Tow, Track model).

Action	Section	Page
<b>DAILY</b>		
Check engine oil level and coolant (ref: engine manual)	6.2 – 6.3	6-4
Check hydraulic oil level	6.4	6-4
Check fuel level	6.5	6-4
Check all drive belts	6.6	6-5
Check condition of blades and retaining bolts	6.7	6-5
<b>Note:</b> Special tools may be required		
Clean radiator screen and around radiator	6.8	6-6
Check feed roller stop bar function	3.4	3-2

<b>First 50 hours</b>		
Check drive belt tensions	6.6 – 6.9	6-5 & 6-6
Check battery levels	6.13	6-7
Check wheel and tyre condition and pressures	6.14	6-8
Check brake condition and operation	6.15	6-8
Check hydraulic connections	6.18	6-8
Check all mountings	6.19	6-9
Check feed roller stop bar function	3.4	3-2
Service engine	Refer to engine manual	

<b>Weekly in addition to Daily actions</b>		
Blow out radiator core with air line	6.8	6-6
Check drive belt tension	6.6 – 6.9	6-5 & 6-6
Steam clean machine	6.10	6-6
Clean air cleaner	6.11	6-7
Check electrical connections	6.12	6-7
Check battery levels	6.13	6-7
Check feed roller stop bar function	3.4	3-2
Check wheel and tyre condition and pressures	6.14	6-7
Check and adjust brakes	6.15	6-8
Grease all bearings and pivots	6.1, 6.16	6-2 & 6-8
Check hydraulic connections	6.18	6-8
Check all mountings	6.19	6-9

<b>250 hours or 12 months, in addition to Daily and Weekly actions</b>		
Check all fluid levels	6.2, 6.3, 6.4	6-4
Check brake condition and operation	6.15	6-8
Check condition of bearings and pivots	6.16	6-8
Service engine	Refer to engine manual	
Check axle mounting bolts for tightness	6.19	6-9
Replace return filter element	6.20	6-9

<b>1000 hours in addition to 250 hour actions</b>		
Change hydraulic oil when replacing filter element	6.21	6-9

**SMART SENSE controller settings Refer to dealer or GreenMech Ltd.**

**ENGINE MAINTENANCE REFER TO ENGINE MANUAL**

**WHEELS AND BRAKES REFER ALSO TO AL-KO CHASSIS MANUAL**  
**All references to wheels and brakes apply also to optional trailers.**

**Tyre Pressure 2.7 bar (40 lb/in<sup>2</sup>)**

<b>Recommended lubricants</b>	<b>Specification</b>
Hydraulic Oil	ISO 32
Grease	Complex grease EP2 (high temperature)
Engine	SAE 15W-40 APICD

6.1 Lubrication Points



Grease except where stated - All models (except where stated)

6.1.1	Drawbar	3 nipples (refer to Alko manual)
6.1.2	Fixed Feed roller bearing	1 nipple behind spare wheel
	Remote nipples on manifold in order from left to right	
6.1.3	Chipper flywheel front bearing	1 nipple on remote manifold
6.1.4	Chipper flywheel rear bearing	1 nipple on remote manifold
6.1.5	Feed roller pivot	1 nipple on remote manifold
6.1.6	Feed roller bearing	1 nipple on remote manifold
6.1.7	Drive belt idler pulley	1 nipple on remote manifold
6.1.8	Chipper flywheel labyrinth seal	1 nipple in flywheel hub (see fig 6.7.1)
6.1.9	Feed Roller stop bar	Clean and grease pivots sparingly

Note 1: Do not over-grease bearings as damage to seals may occur.  
 40 hours requires only one full pump of hand operated cartridge gun.  
 Note 2: Use high temperature grease on chipper flywheel bearings.

**6.2 Engine Oil (Under engine cover)**

Check daily (fig 6.2). Refer to engine manual to refill.

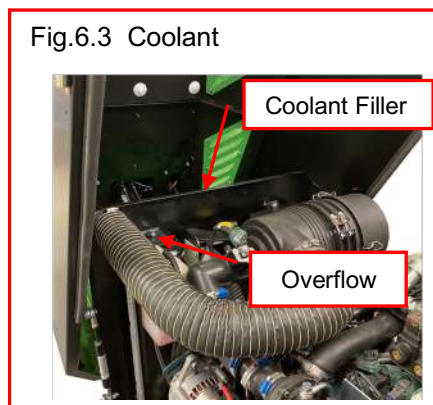
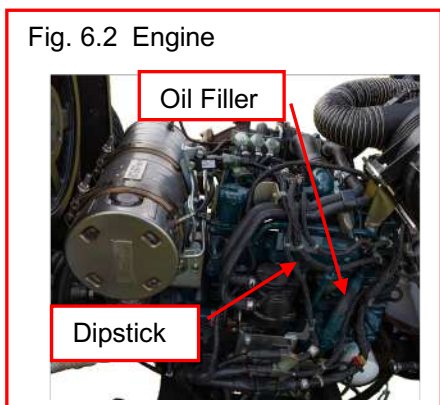

**6.3 Coolant (under Engine cover)**

Check daily, both radiator and overflow tank (fig 6.3). Refill as required. Check antifreeze.

**⚠ CAUTION!** Do not remove cap when engine is hot.

**6.4 Hydraulic Oil**

Check daily (fig 6.4). If below mark, check for leaks and refill to correct level.

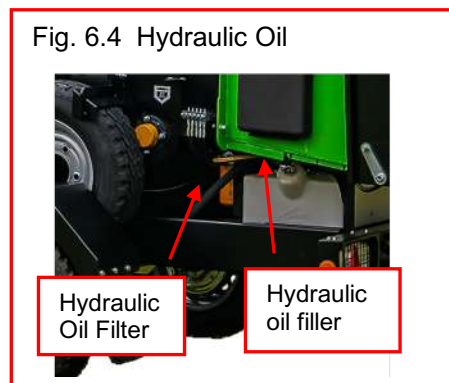

**1000 hours.** Change oil (see 6.21). Replace filter (6.20).

**6.5 Fuel Level (Section 4.1)**

Check daily before work and fill as required.

**⚠ CAUTION!** Use clean fuel only. If in doubt, use a funnel with a filter.

**⚠ CAUTION!** Do not use any form of synthetic fuel.

**6.6 Drive Belts (under engine cover)**

Check daily before work (Fig 6.6) condition of all drive belts and replace if worn. See section 6.9 for adjustment and replacement instructions.

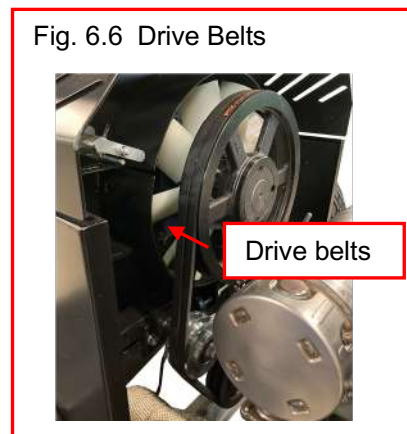

6.7 Disc Blade Cleaning - Replacement

Blade design permits relocation in at least two rotated positions before regrinding or replacement is required.

- 1 Check engine is switched off, and start key removed.
- 2 Raise engine cover, and check any rotation has stopped.

**⚠ CAUTIONS for Blade cleaning**

- Blades have sharp edges. Wear protective gloves.
- Flywheel paddles and vanes create shearing and trapping points at edges of exposed housing. Do not place hands or fingers on or near flywheel and housing edges.
- Flywheel rotation is resisted by engine compression in either direction. Beware unexpected movement when manually rotating flywheel between blade positions.
- Tools can slip if not fully engaged. Clean fasteners thoroughly before applying tools.
- Ensure flywheel is prevented from rotating when applying force to tools on blade fasteners.

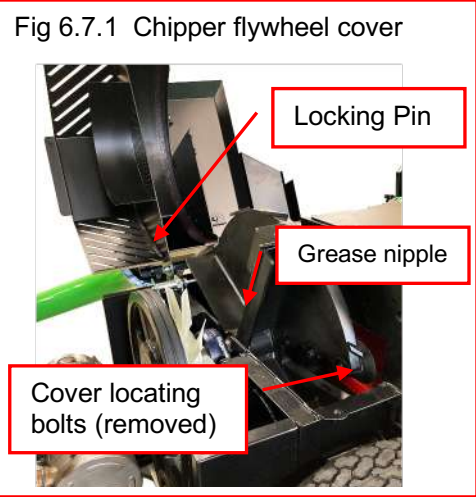

Follow procedure as on symbol instructions on machine (Section 3.8):

- 1) Wear protective gloves.
- 2) Remove flywheel cover bolts.
- 3) Using discharge chute handle as a lever, swing back cover on to stop to expose flywheel and blades. (fig 6.7.1).
- 4) Locate and retract flywheel locking pin, and carefully turn flywheel until locking pin engages hole (2 positions) in flywheel to prevent movement).
- 5) Thoroughly clean debris from nut faces and bolt head socket.
- 6) Using socket tool, loosen nut anticlockwise. Support blade bolt with hexagon key as required and remove blade and fasteners (fig 6.7.2).
- 7) Thoroughly clean debris from flywheel blade housing and all components to be replaced. Inspect condition of nuts and bolts and replace if any signs of wear. (Fig 6.7.3 and fig 6.7.4)
- 8) Replace blade with Nord-Lock washers ensuring that flywheel is blocked for opposite rotation. Tighten to correct torque: 200Nm.
- Retract locking pin and carefully rotate to next blade and repeat next blade removal (from 4 above) until all blades cleaned and replaced securely.
- 9) Replace all covers.
- 10) Check all covers are secure.
- 11) Replace key to start machine.

**⚠ CAUTION! Blades must only be sharpened by grinding angled back face on a bench grinder. Grinding of front face will upset gap, which is factory set. Do not sharpen with hand held equipment.**

All blades must be sharpened in “sets” with equal amounts removed to maintain balance. See 6.24

Note. If any blades are worn below flat annular section a complete set should be replaced.

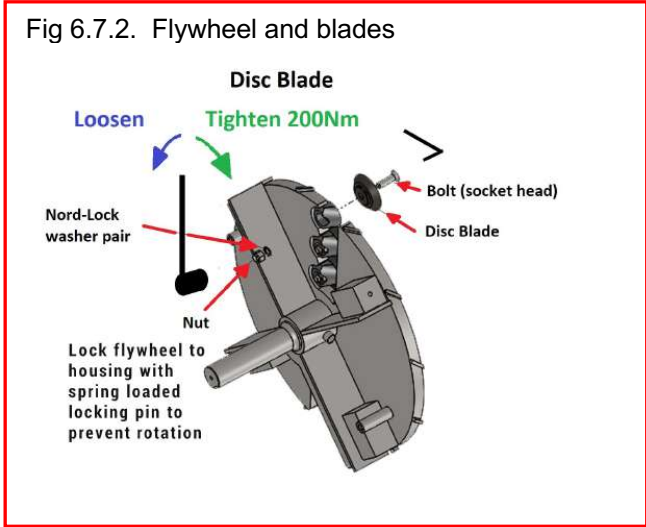

**6.8 Radiator)**

**Daily**

Check radiator for debris. (fig.6.8)

Lift out guard and clean.

**50 hours or weekly**

In addition to above, blow out radiator core from back with suitable airline, lift up front grille and clear from front.

**⚠ CAUTION! A build up of debris risks overheating of engine and a risk of fire.**

Fig.6.8 Radiator guard



**6.9 Drive belts Chipper flywheel drive**

**Belt Adjustment and Replacement**

Remove engine cover.

1) Release bracket bolts and tensioner (fig 6.9) to adjust or remove belts.

2) Re-tension belts and tighten bracket bolts to secure.

Replace worn belts with new set, ensuring bedded in pulley grooves, and reset tension.

Check alignment and tension before starting chipper.

Fig.6.9 Chipper belt tensioner

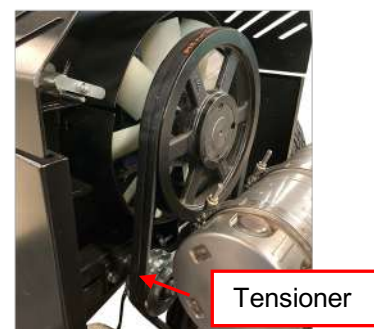

**6.10 Steam Cleaning**

**Weekly and every 250 hours or 12 months**

1) Check all covers are fitted and closed.

2) Steam clean machine surfaces.

3) Clean electrical components with a damp rag, spray with WD40 and then wipe with dry rag.

**⚠ CAUTION! Do not steam clean directly on to electrical components, e.g. control boxes.**

**6.11 Air Cleaner (under engine cover)**

**Weekly (Refer to engine manual)**

1) Remove cover screw or clips (fig 6.11) and release.

2) Slide out element and either blow out with air-line or gently tap on smooth ground to release debris.

3) Replace cover.

Fig 6.11 Air Cleaner



**6.12 Electrical connections**

**Weekly**

Check all wiring loom connections are secure.

**⚠ CAUTION! Poor connections will affect engine security cut-outs and may prevent starting.**

**6.13 Battery****First 50 hours and weekly (Fig 6.13)**

- 1) Remove right hand side covers (above road wheel) to access battery.
- 2) Release stays if necessary.
- 3) Check electrolyte level and top up if required.
- 4) Reposition battery, and secure stays.
- 5) Refit cover and secure.

**Removal**

- 1) First disconnect negative (-) cable (black cap).
- 2) Disconnect positive (+) cable (red cap).
- 3) Remove clamp and carefully lift out battery.
- 4) Replace by connecting positive cable before negative.
- 5) Secure battery as 6.13.4 above.

Fig 6.13 Battery

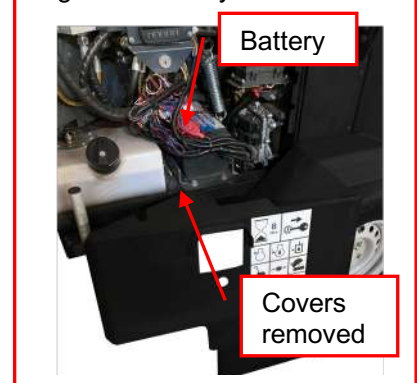

**CAUTION!** Gases are explosive. Electrolyte is corrosive. Avoid sparks and spillage.

**6.14 Tyres and Wheels****50 hours and 250 hours or 12 months**

Check condition of tyres.

Check pressures and inflate to 2.7bar (40lb/in<sup>2</sup>) pressure as required.

Check wheel nuts are tight to 110Nm (80lbft) torque.

**6.15 Brakes****50 hours, weekly and 250 hours or 12 months**

Check operation and effectiveness of overrun and handbrake.

**100 hours****Adjust brakes as follows:**

- 1) Chock machine, release handbrake fully off and check drawbar is fully extended.
- 2) Jack up both wheels and support on axle stands.
- 3) Remove inner bung (fig 6.15.1) to expose adjuster 'starwheel'.
- 4) Adjust starwheel with screwdriver until tight whilst rotating each wheel forwards until tight.
- 5) Slacken until wheel rotates freely in forward direction.

Fig 6.15.1 Brake adjustment



**CAUTION!** Reverse rotation of wheel may prevent correct adjustment.

- 6) Check brake linkage has 4 to 6mm movement at cable.
  - 7) Repeat for opposite wheel.
  - 8) Check balance bar is straight and pulls both cables evenly (fig 6.15.2).
  - 9) Adjust ball nut to remove any slack from brake rod.
- Note:** Servicing of brakes may be required more often if above average mileage is covered.  
Refer to AL-KO brake manual or GreenMech for details for brake shoe replacement and other servicing

Fig 6.15.2 Brake adjustment

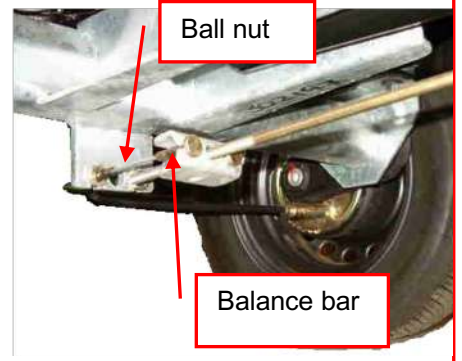
**6.16 Bearings and Pivots**  
**weekly**

See paragraph 6.1 for routine lubrication.

**250 hours or 12 months**

Check rotating components for excessive movement and noise in operation.  
Replace as required.

**Note:** Wheel bearings are maintenance free and do not require attention.

**6.17** *Number not used.***6.18 Hydraulic connections****50 hours**

With circuit diagram to follow hose routings, check all hoses and connections for leaks and damage.

Replace any worn or damaged hoses with correct type and length.

Check routing before removal.

Replace hose free of strains, twists or kinks.

**CAUTION!** Ensure any residual pressure is released before dismantling.

**CAUTION!** Ensure hoses are refitted free of twists and kinks.

**6.19 Mountings****250 hours**

Check that all mounting bolts are tight.



**6.20 Hydraulic Return Filter**  
**250 hours or 12 months (Fig 6.20)**

- 1) Check oil is cool.
- 2) Remove spare wheel to access canister.
- 3) Unscrew canister and discard safely (fig 6.20).
- 4) Fit new filter canister.

**⚠ CAUTION! Do not overtighten.**

- 5) Refit and secure spare wheel.

Fig 6.20 Hydraulic return filter

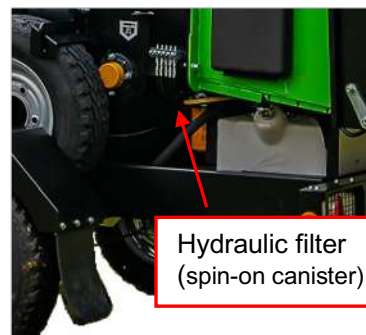

**6.21 Hydraulic Oil change**  
**1000 hours**

Remove hydraulic oil with suction pump at filler.  
 Replace suction filter.  
 Replace with new oil and filter of correct specification.  
 Dispose of waste oil according to local authority environmental procedures.

**6.22 Fuses and No Stress system**

There are two fuses.  
 A 40 amp in-line fuse protects engine pre-heat and start circuit.  
 A 20 amp fuse protects No Stress Power Protection System.  
 Note Operating speeds for No Stress system are factory set for particular machine models.

**6.23 Fault finding**

Fault	Check	Action	Page
Smart Sense controller	If not functioning as expected, refer to dealer or GreenMech. There are no operator interventions available.		
Engine will not start	Battery	Recharge	6-8
	Fuel	Fill tank	6-5
	Oil pressure	Check Oil level	6-5
	Thermal cut-out	Check operation	6-5
	Fuses	Check	6-11
Engine not at correct speed	Engine control	Refer to dealer or GreenMech	5-2
Chipper flywheel will not start	Drive belts	Replace	6-7
Feed rollers do not turn	Stop bar	Check	3-2
	Stop button	Release	3-2
	Hydraulics	Check solenoid valve	5-2
Feed will not reverse	Stop bar	Reset and check	3-2
	Hydraulic valve	Check operation	
Discharge does not flow	Discharge chute	Check for blockage	5-3
	Chipper flywheel	Check for blockage	5-3
Unusual noise(s)	Chipper flywheel and bearings	Check and replace	5-3
			6-9

6.24 Chipper Disc Blade Re-grinding

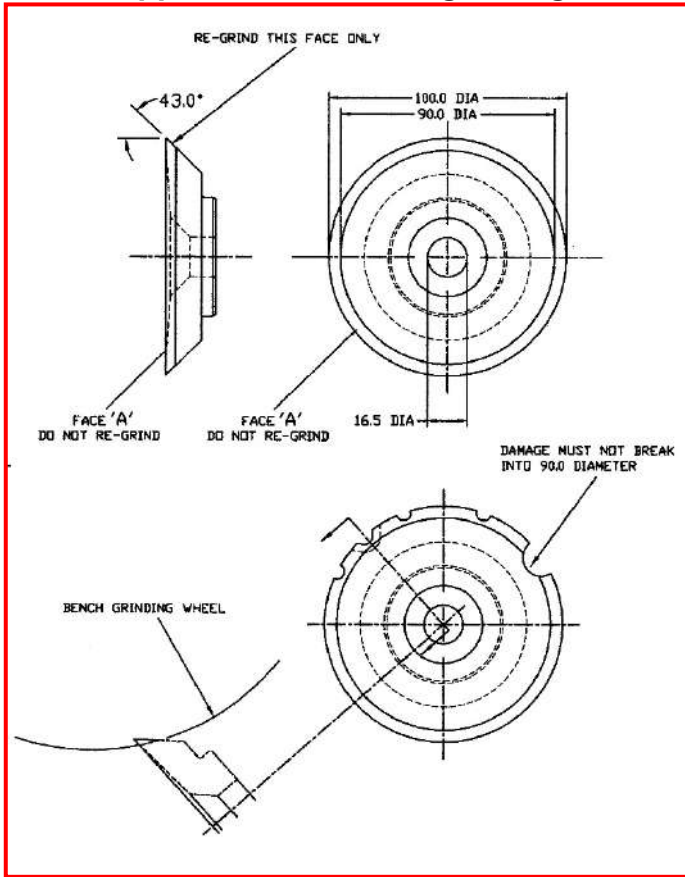

Examine set of chipper disc blades for damage. If front face 'A' is worn, blade must be scrapped. If chips have broken off cutting edge they can be re-dressed provided that they do not go inside 90mm diameter area.

Always regrind worst damaged blade first, as this will establish target weight for remaining blades. If large chips exist over less than 30% of circumference, blade may be re-ground provided large damaged area is not used for chipping. Chips may be repaired by grinding a cutting edge around damaged area using a bench grinder. With chipper blade mounted on a mandrel re-grind remainder of cutting edge at 43° as shown. Re-grind in increments of approximately 0.01mm (0.004") until sharp edge is restored.

If re-grinding breaks into 90mm diameter area, blade must be scrapped.

After re-grinding weight of blades within a set must not vary by more than +/- 1gm (0.03oz). Weight of each blade must not be less than 560gm (20oz)

**Note:** Disc Blades use a patent Nord-Lock washer pair together with a thinner Nyloc type locking nut at an increased torque setting of

200Nm.

See fig 6.7.3 and Fig 6.7.4.

Ensure that both washers are assembled as a pair with faces of fewer teeth facing each other (fig 4). Thread lubricant is recommended to ensure even torque. Do not use thread adhesive (e.g. Loctite).

**Reuse:**

Nord-Lock washers can normally be re-used when cleaned and re-lubricated.

Nyloc nuts should always be inspected for damage before reuse.

6.25 Shear Bar removal (with slide hammer) and turning

- 1) Remove spare wheel and shear bar end cover.
- 2) Attach slide hammer to exposed thread in shear bar.
- 3) Carefully ease out bar with hammer (fig 6.25).
- 4) Turn bar to new cutting edge or replace.
- 5) Refit bar
- 6) Replace end cover and spare wheel.

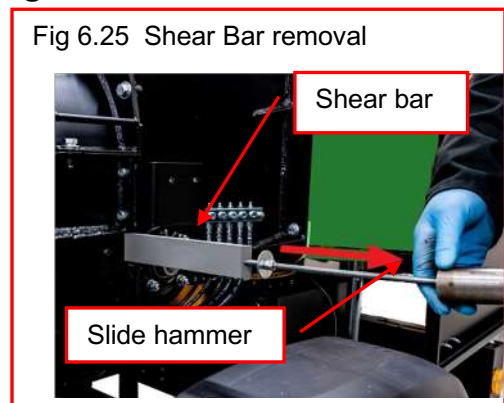

## **7.1 Storage**

Thoroughly clean machine and note any replacement parts required.

Carry out 250 hour service if not already done. Refer to Section 6

Fit replacement parts when available.

Remove battery (where fitted)

Refer to 6.13

Drain fuel

If machine is to be stored for more than 3 months, place on axle stands to remove weight from wheels\*.

Fold down discharge chute if necessary.

## **7.2 Removal from Storage**

Service engine

Refer to engine manual

Charge battery and refill

Refer to 6.13

Check tyre pressures (as applicable)

Refer to 6.14

Check brake operation (as applicable)

Refer to 6.15

Carry out machine preparation as necessary

Refer to Section 4

## **8 Disposal**

When machine is finally scrapped, the following items should be disposed of only at authorised waste disposal facilities.

Engine oil. Hydraulic oil. Antifreeze. Battery. Tyres.

If in doubt, consult Local Authority environmental department.

Major non-ferrous items such as covers and hydraulic hoses may also be disposed of separately.

# GreenMech

The Professionals' Choice



01789 400 044    [support@greenmech.co.uk](mailto:support@greenmech.co.uk)    [www.greenmech.co.uk](http://www.greenmech.co.uk)

GreenMech Ltd, The Mill Industrial Park, Kings Coughton,  
Alcester, Warwickshire B49 5QG

[www.greenmech.co.uk](http://www.greenmech.co.uk)